

Service Manual

Portable Stereo CD System

Radio Cassette

*1  DOLBY SYSTEM*2 **MASH**
multi-stage noise shaping

COMPACT
disc
DIGITAL AUDIO

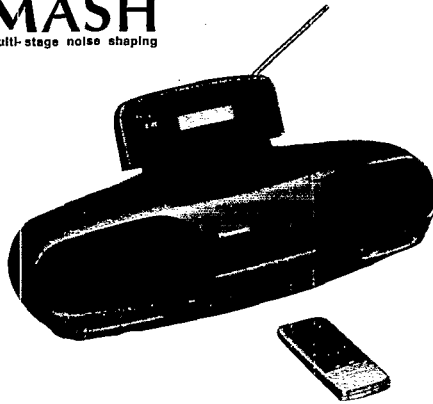

RX-DT707

Colour

(K) Black Type

Areas

Suffix for Model No.	Area	Colour
(EB)	Great Britain	(K)
(EG)	Europe and Germany	

TAPE DECK: RX-FD55 MECHANISM SERIES (AR300)
TRAVERSE DECK: SL-CH550 MECHANISM SERIES (RAE0111Z)

■ SPECIFICATIONS

General:

Power Requirement: AC; 230~240 V, 50 Hz
 Battery; 15 V (10 R20/LR20, UM-1 batteries)
 Memory Back-up for Computer/Clock;
 6 V (4 R6/LR6, UM-3 batteries)

Power Consumption: 57 W

Power Output: Low ch; 11.6 W×2 (PMPO)
 High ch; 4.2 W×2 (PMPO)

Speaker: Woofer; 10 cm PM Dynamic speaker
 2.7Ω

Squawker Tweeter; 8 cm PM Dynamic speaker 8Ω

Inputs: MIX MIC; 2.5 mV, 200~600Ω, Ø3.5
 AUX; 200 mV, 47 kΩ

Outputs: HEADPHONES; 32Ω, Ø3.5
 CD OUT; 1 V (CD 0 dB)

Dimensions: 710 (W)×205 (H)×263 (D) mm
 (When the top panel is open)
 8.0 kg without batteries

Weight:

Disc Player Section:

Sampling Frequency: 44.1 kHz

Decoding: 16-bit linear

Beam Source: Semiconductor laser
 (wavelength 780 nm)

No. of Channels: 2 channels, stereo

Frequency Response: 20~20,000 Hz (+1, -2 dB)

Wow and Flutter: Unmeasurable

D/A Converter: MASH (1 BIT DAC)

Radio Section:

Frequency Range: FM; 87.5~108 MHz

LW; 144~288 kHz

MW; 522~1611 kHz

Intermediate Frequency: FM; 10.7 MHz

AM (LW/MW); 459 kHz

FM; 5 μV/0.1 mW output
 (-3 dB Limit Sens.)

LW; 100 μV/m/0.1 mW output (Max.)

MW; 56.3 μV/m/0.1 mW output (Max.)

Tape Deck Section:

Frequency Range: 30~16,000 Hz (with normal tape)

30~17,000 Hz (with CrO₂ tape)

30~18,000 Hz (with METAL tape)

Recording System: AC bias, AC erase (Deck 2)

Tape Speed: 4.8 cm/sec.

Monitor System: Variable sound monitor

Track System: 4-track 2-channel stereo recording and
 playback

*1 **Dolby noise reduction manufactured under license from Dolby Laboratories Licensing Corporation.**
 "Dolby" and the double-D symbol are trade marks of Dolby Laboratories Licensing Corporation.

*2 **Technics (or Panasonic) developed the world's first MASH type DAC and ADC. MASH technology was invented by NTT (LSI Labs).**
MASH is a trademark of NTT.

Notes:

- Weights and dimensions shown are approximate.
- Design and specifications are subject to change without notice.

Panasonic

■ CONTENTS

	Page
• PRECAUTION OF LASER DIODE	2
• LOCATION OF CONTROLS	3~5
• TIME ADJUSTING	6
• DISASSEMBLY INSTRUCTION	7~18
• SCHEMATIC DIAGRAM	19~34
• PRINTED CIRCUIT BOARD DIAGRAM	35~41
• WIRING CONNECTION DIAGRAM	42, 43
• PREPARATIONS FOR CHECK AND ADJUSTMENT OF P.C.B.	44~48
• MEASUREMENTS AND ADJUSTMENTS	49~52

	Page
• NEW DIGITAL SERVO CIRCUIT	53
• SELF DIAGNOSTIC FUNCTION	54
• TROUBLESHOOTING GUIDE	55~56
• FUNCTION OF IC TERMINALS	57~61
• BLOCK DIAGRAM	62~68
• REPLACEMENT PARTS LIST	69~78, 85, 86
• PACKAGING	72
• CABINET PARTS LOCATION	79, 80
• MECHANISM PARTS LOCATION	81~84
• LOADING UNIT PARTS LOCATION	87

■ PRECAUTION OF LASER DIODE

CAUTION: This product utilizes a laser diode with the unit turned "on", invisible laser radiation is emitted from the pick up lens.
Wave length: 780 nm
Maximum output radiation power from pick up: 100 μ W/VDE

Laser radiation from the pick up unit is safety level, but be sure the followings:

1. Do not disassemble the optical pick up unit, since radiation from exposed laser diode is dangerous.
2. Do not adjust the variable resistor on the pickup unit. It was already adjusted.
3. Do not look at the focus lens using optical instruments.
4. Recommend not to look at pick up lens for a long time.

ACHTUNG: Dieses produkt enthält eine laserdioden. Im eingeschalteten zustand wird unsichtbare laserstrahlung von der lasereinheit abgestrahlt.

Wellenlänge: 780 nm
Maximale strahlungsleistung der lasereinheit: 100 μ W/VDE

Die strahlung an der lasereinheit ist ungefährlich, wenn folgende punkte beachtet werden:

1. Die lasereinheit nicht zerlegen, da die strahlung an der freigelegten laserdioden gefährlich ist.
2. Den werksseitig justierten einstellregler der lasereinheit nicht verstellen.
3. Nicht mit optischen instrumenten in die fokussierlinse blicken.
4. Nicht über längere zeit in die fokussierlinse blicken.

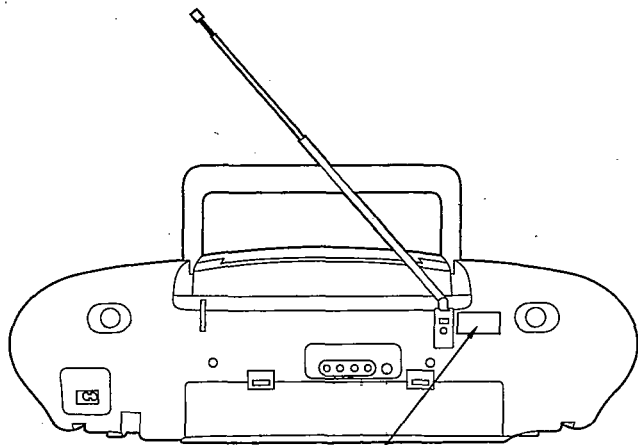

**CLASS 1
LASER PRODUCT**

**LUOKAN 1 LASERLAITE
KLASS 1 LASER APPARAT**

**ADVARSEL: USYNTLIG LASERSTRÅLING
VED ÅBNING, NÅR SIKKERHEDSAF-
BRYDERE ER UDE AF FUNKTION.
UNDGÅ UDSÆTTELSE FOR STRÅLING.**

**VARO! Avattaessa ja
suojalkitus ohitettaessa
olet alttiina näkymätön
lasersäteilylle.
Älä katso säteeseen.**

**VARNING! Osynlig
laserstråling när denna
del är öppnad och
spårren är urkopplad.
Betrakta ej strålen.**

**VORSICHT- Unsichtbare
Laserstrahlung, wenn
Abdeckung geöffnet.
Nicht dem Strahl
aussetzen.**

**DANGER- Invisible
laser radiation when
open.
AVOID DIRECT EX-
POSURE TO BEAM.**

**ADVERSEL! Usynlig
laserstråling når deksel
åpnes og sikkerheds-lås
brytes. Unngå
eksponering for strålen.**

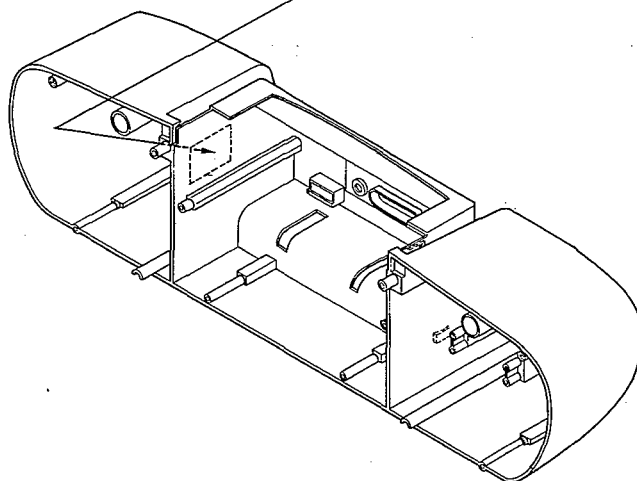

LOCATION OF CONTROLS

The functions indicated by the numbers with black back ground (for example ③) can also be activated from the remote control transmitter. (See page 5.)

CD/GENERAL CONTROLS

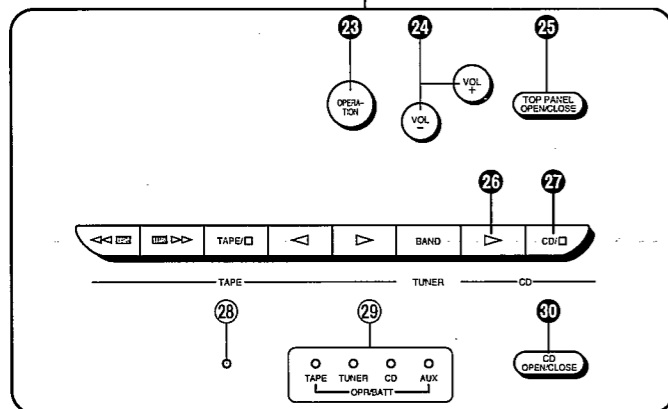
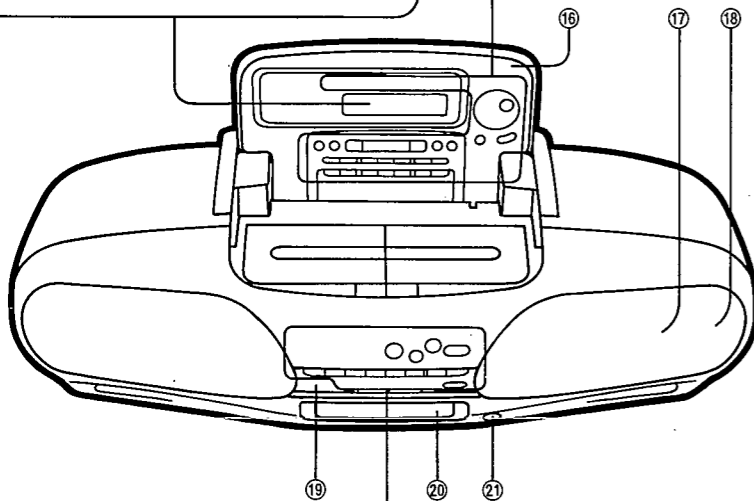
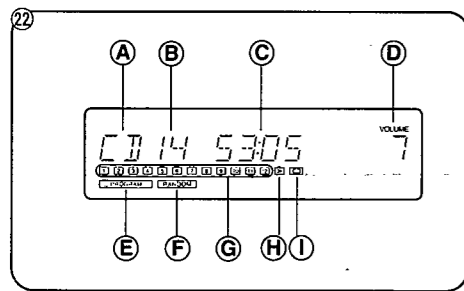
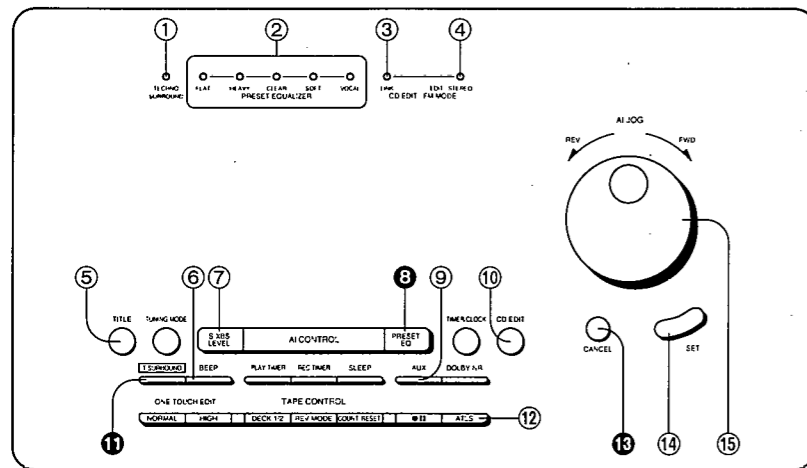

- ① Surround indicator (TECHNO SURROUND)
- ② Preset equalizer mode indicator (PRESET EQUALIZER)
- ③ Link edit indicator (LINK)
- ④ CD edit/stereo indicator (EDIT/STEREO)
- ⑤ Title button (TITLE)
- ⑥ Beep sound button (BEEP)
The beep sound (beep) will be emitted each time the operation button is pressed. The beep function can be turned on and off by pressing this button.
- ⑦ Super extra bass system button (S-XBS LEVEL)
- ⑧ Preset equalizer button (PRESET EQ)
- ⑨ Aux button (AUX)
- ⑩ Compact disc edit button (CD EDIT)
Press this button to select the desired edit mode.
- ⑪ Surround function button (T-SURROUND)
- ⑫ Automatic tape level setting button (ATLS)
Press this button to begin the recording from a CD.
- ⑬ Cancel button (CANCEL)
- ⑭ SET button (SET)
- ⑮ Jog dial (AI JOG)
- ⑯ Top panel
- ⑰ Speakers [Woofer] (10 cm, 2.7Ω)
- ⑱ Speakers [Squawker Tweeter] (8 cm, 8Ω)
- ⑲ Remote control sensor
- ⑳ Disc tray
- ㉑ Headphones jack (PHONES) (∅3.5, 32Ω)
- ㉒ Display section
 - A: CD mode indicator
 - B: Track display
 - C: Playing time display
 - D: Volume level display (VOLUME)
 - E: Program indicator (PROGRAM)
 - F: Random indicator (RANDOM)
 - G: Music matrix
 - H: Over mark indicator (▶)
 - I: Repeat indicator (◀)
- ㉓ Operation switch (OPERATION, OFF/ON)
- ㉔ Volume control (VOL.)
- ㉕ Top panel open/close button (TOP PANEL OPEN/CLOSE)
- ㉖ Play button (▶)
Press this button to start the disc play.
- ㉗ CD mode/stop button (CD/□)
Press this button to listen to the CD or to stop the CD playing.
- ㉘ AC connection indicator
While the AC mains supply is used, it lights as an AC connection indicator.
- ㉙ Play mode/operation/battery check indicators
It functions as a battery check indicator when the unit is operated on batteries.
- ㉚ CD open/close button (CD OPEN/CLOSE)

TUNER CONTROLS

- ㉓ Tuning mode button (TUNING MODE)
- ㉔ Tuner/band button (TUNER, BAND)
Press this button to select the desired radio band.
- ㉕ Display section
 - A: Band indicator (FM/MW/LW)
 - B: Frequency display
 - C: Channel number indicators
 - D: Program indicator (PROGRAM)
 - E: Tuning indicator (TUNED)
 - F: Stereo indicator (STEREO)

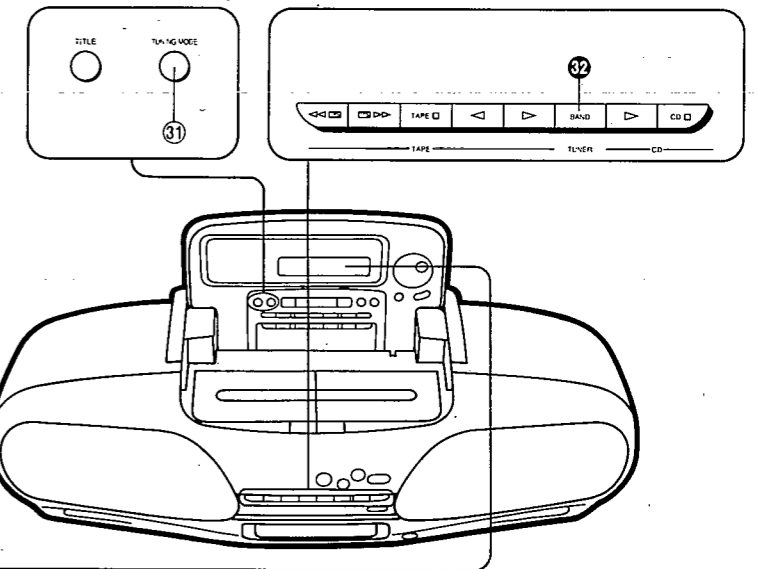
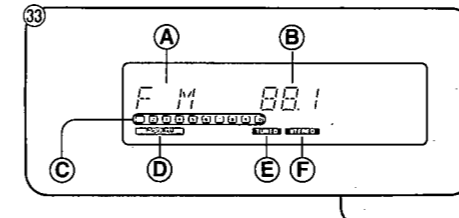

DECK CONTROLS

- ㉖ Edit recording buttons (ONE TOUCH EDIT)
Press one of these buttons to start the synchronized edit recording.
- ㉗ Deck 1/2 selector (DECK 1/2)
Press this button to select the operation deck (deck 1 or 2).
- ㉘ Reverse mode select button (REV MODE)
- ㉙ Counter reset button (COUNT RESET)
Press this button to reset the tape counter.
- ㉚ Rec-pause button (●||)
- ㉛ Dolby NR button (DOLBY NR)
- ㉜ Deck 1 cassette eject button (▲ EJECT)
- ㉝ Deck 1 cassette compartment cover
- ㉞ Deck 2 cassette compartment cover
- ㉟ Deck 2 cassette eject button (▲ EJECT)
- ㊱ Fast/tape program sensor buttons (◀◀ TPS ▶▶)
Press one of these buttons to fast forward or rewind the tape during stop condition, or to skip to the beginning of the next or present tune during playback.
- ㊲ Tape mode/stop button (TAPE/□)
Press this button to listen to tapes or to stop the tape.
- ㊳ Reverse-side playback button (◀)
Press this button to begin the playback (or recording) from the reverse side of the tape.
- ㊴ Forward-side playback button (▶)
Press this button to begin the playback (or recording) from the forward side of the tape.
- ㊵ Display section
 - A: Tape mode indicator (TAPE)
 - B: Tape counter
 - C: Running indicator
 - D: Deck 1/2 indicators (DECK 1 DECK 2)
 - E: Reverse mode indicator (◀)
 - F: Dolby NR indicator (DOLBY NR)
 - G: Recording indicator (REC)
 - H: Tape direction indicators (◀◀ ▶▶)

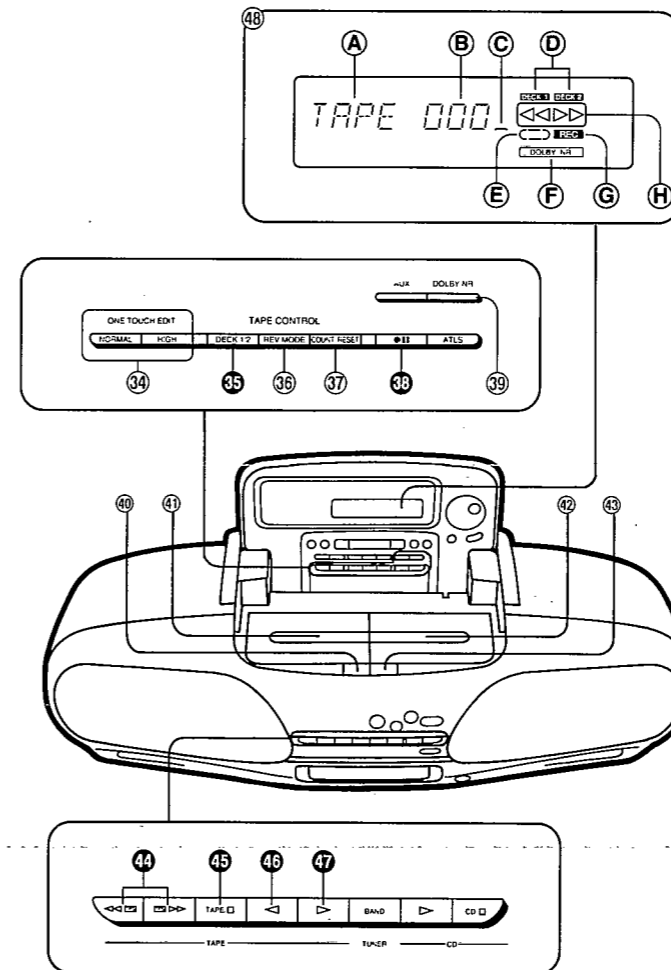

●TIMER CONTROLS

- ④9 **Timer play button (PLAY-TIMER)**
Press this button for timer play.
- ⑤0 **Timer recording button (REC-TIMER)**
Press this button for timer recording.
- ⑤1 **Sleep button (SLEEP)**
Press this button when you wish to fall asleep while listening to music.
- ⑤2 **Timer clock button (TIMER/CLOCK)**
- ⑤3 **Display section**
A: Timer ON indicator (ON)
B: Timer play indicator (TIMER)
C: Timer recording indicator (TIMER-REC)
D: Timer OFF indicator (OFF)
E: Sleep timer indicator (SLEEP)
F: Time display

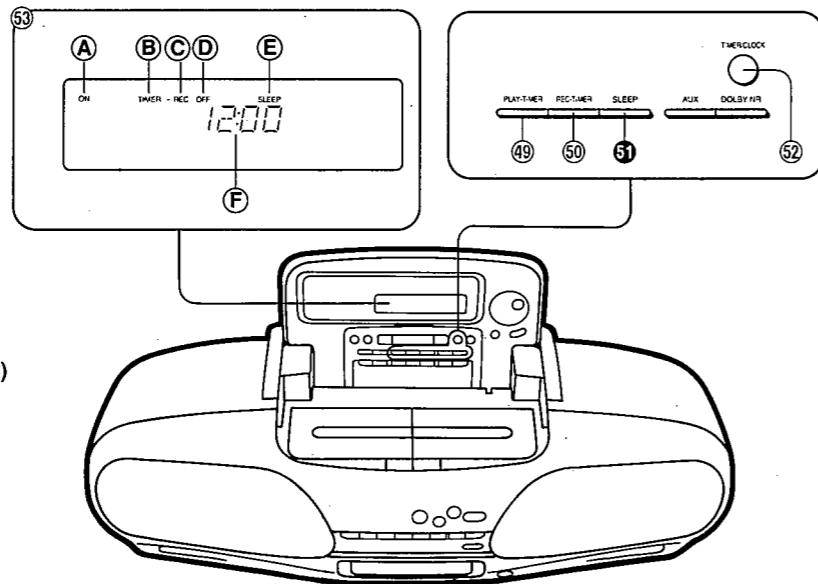

●REAR PANEL SECTION

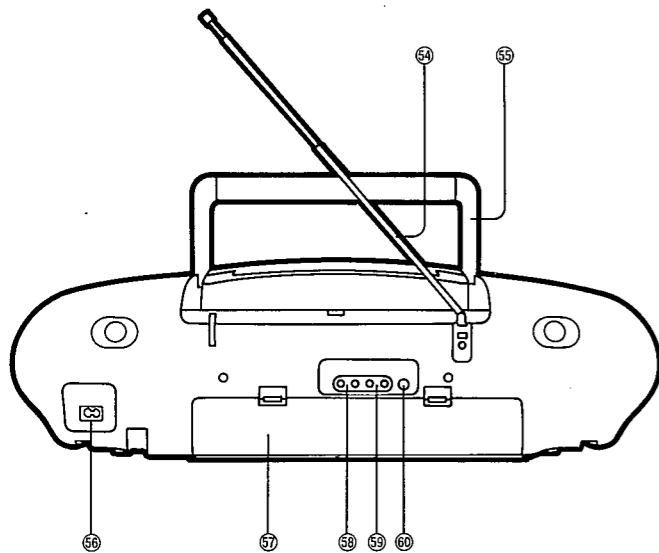

- ⑤4 Telescopic antenna
- ⑤5 Handle
- ⑤6 AC socket (AC IN~)
- ⑤7 Battery compartment cover
- ⑤8 Aux input jacks (AUX IN) (200 mV, 4.7 kΩ)
- ⑤9 CD output jacks (CD OUT) (1 V, CD 0 dB)
- ⑥0 Mixing microphone jack (MIX MIC)
(∅3.5, 200~600Ω)

- ⑥7 **Display button (DISPLAY)**
Press this button when you wish to confirm the present time while listening to CD, radio and tape.
- ⑥8 **Skip/search buttons (◀◀/▶▶, ▶▶/▶▶)**
Press one of these buttons to skip (backward or forward) the tracks, or to search (backward or forward) the desired portion of the disc.

●REMOTE CONTROL OPERATION

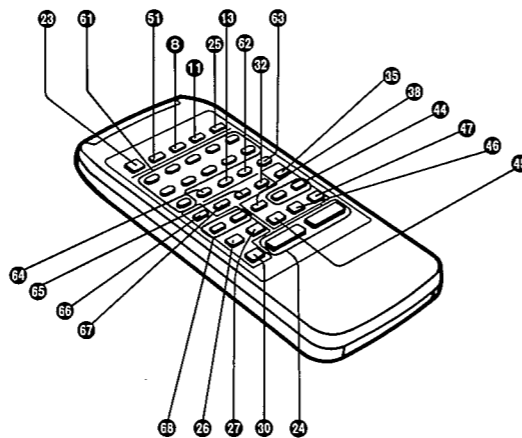

- ⑥1 **Numeric buttons (1-10/0, +10)**
These buttons are used to specify the CD's track (1-10, +10), and select the preset memory channel of the tuner (1-10).
- ⑥2 **Random button (RANDOM)**
Press this button to let the microcomputer make a random selection of the sequence.
- ⑥3 **Repeat button (REPEAT)**
Press this button to activate the repeat mode. The repeat indicator will appear.
- ⑥4 **Program button (PROGRAM)**
Press this button for CD program-play and for preset memory of the tuner.
- ⑥5 **FM mode/beat proof button (FM MODE/B.P)**
The functions of this button change according to the selected radio band.
MW/LW: Beat proof
(for recording from the MW/LW radio)
FM: MONO/STEREO
- ⑥6 **Pause button (||)**
Press this button to stop the disc temporarily.

■ TIME ADJUSTING

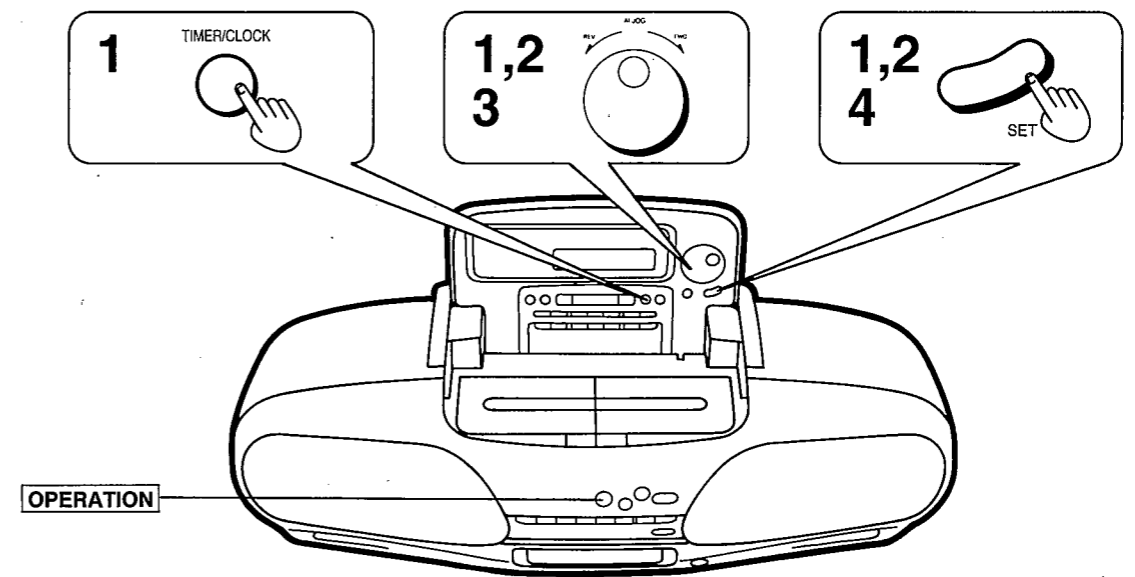

OPERATION

Before operation, press the operation switch to turn on the unit.

For example:
To set the time at 16:20.

- 1 Press the timer/clock button, and then turn the jog dial to select the "CLOCK" mode.
The display will change to "P-TIMER"-"R-TIMER"-"SLEEP"-"CLOCK".

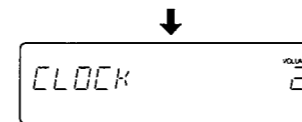
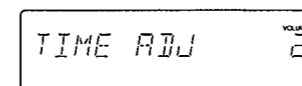

Press the SET button.

- 2 Turn the jog dial to adjust the correct hour display.
FWD: Increase.
REV: Decrease.

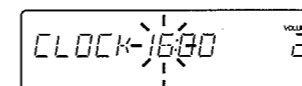

Flashing

Press the SET button.

- 3 Turn the jog dial to adjust the correct minute display.
Note that the minute "00" display appears following "59", but the hour display is not changed.

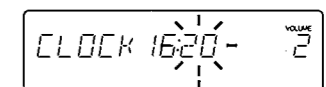

Flashing

- 4 Press the SET button to finish setting the time.
The display will change to the previous display.

When the SET button is pressed, the clock is reset to "0" second.
When a wrong operation occurs while operations of steps 1~3, press the cancel button, then the unit is returned to the previous mode.

HANDLING PRECAUTIONS FOR TRAVERSE DECK

The laser diode in the traverse deck (optical pickup) may break down due to potential difference caused by static electricity of clothes or human body.

So, be careful of electrostatic breakdown during repair of the traverse deck (optical pickup).

Handling of traverse deck (optical pickup)

1. Do not subject the traverse deck (optical pickup) to static electricity as it is extremely sensitive to electrical shock.
2. To prevent the breakdown of the laser diode, an anti-static shorting pin is inserted into the flexible board (FPC board). When removing or connecting the short pin, finish the job in as short time as possible.
3. Take care not to apply excessive stress to the flexible board (FPC board).
4. Do not turn the variable resistor (laser power adjustment). It has already been adjusted.

Grounding for electrostatic breakdown prevention

1. Human body grounding
Use the anti-static wrist strap to discharge the static electricity from your body.
2. Work table grounding
Put a conductive material (sheet) or steel sheet on the area where the traverse deck (optical pickup) is placed, and ground the sheet.

Caution:

The static electricity of your clothes will not be grounded through the wrist strap. So, take care not to let your clothes touch the traverse deck (optical pickup).

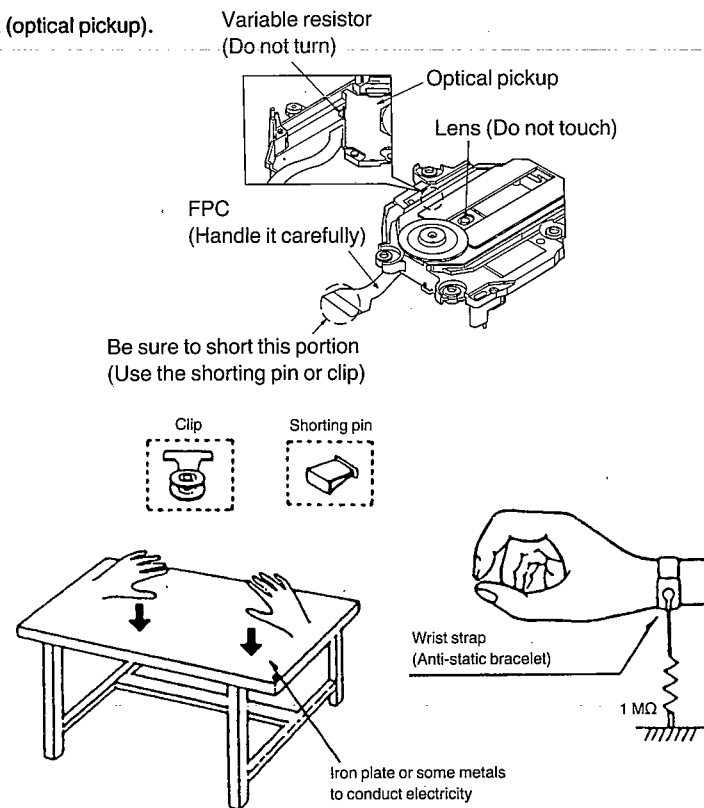

DISASSEMBLY INSTRUCTIONS

- Use a phillips screwdriver whose blade is 13 cm long and over to remove screws fixing the rear cabinet.

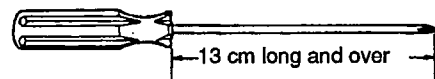

- Be sure to place the unit on soft cloth or similar material to prevent scratches when disassembling it.

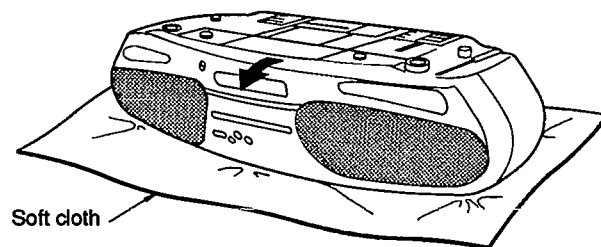

Ref. No. 1 Removal of the Handle

Procedure 1

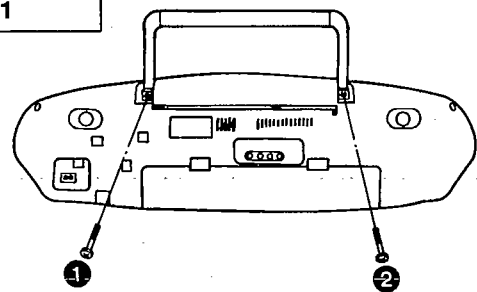

1. Remove 2 screws (1, 2).

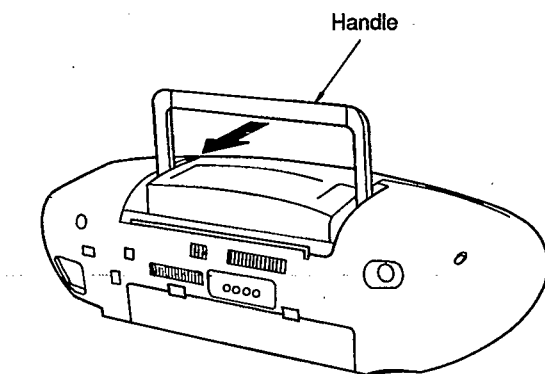

2. Slide out the handle in the direction of the arrow.

Ref. No. 2 Removal of the Front Cabinet

Procedure 1→2

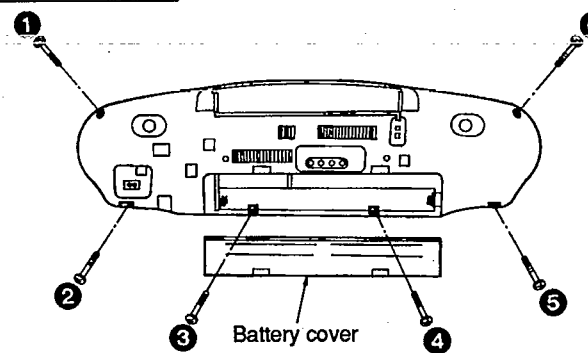

1. Remove the battery cover.
2. Remove 6 screws (1-6).

Notes:

1. Note that the two claws (shown in the right figure) hook the front cabinet when removing the front cabinet.
2. Be careful not to bend pins of the speaker output connector (CP605).

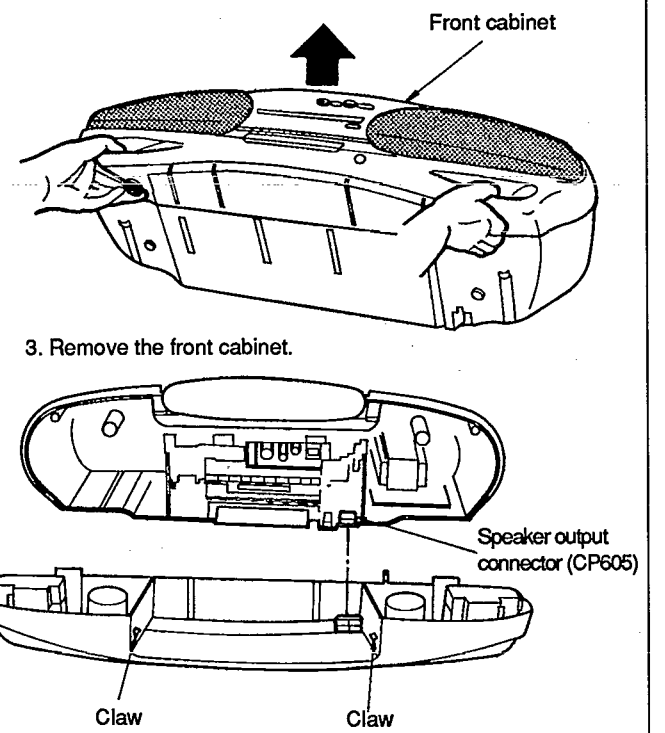

3. Remove the front cabinet.

Ref. No. 3 Removal of the Operation P.C.B.

Procedure 1→2→3

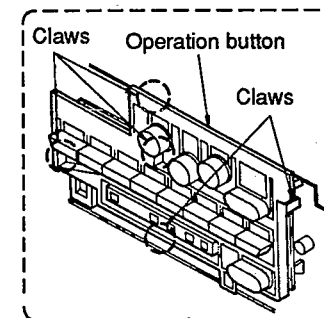

1. Release 5 claws.
2. Remove the operation button.

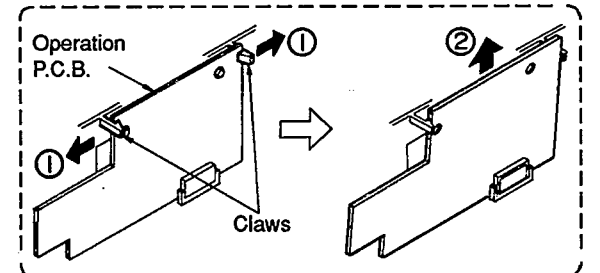

3. Remove 2 screws (1, 2).
4. Remove 2 claws in the direction of arrow 1.
5. Remove the operation P.C.B. in the direction of arrow 2.

Ref. No. 4 Removal of the Main Unit

Procedure 1→2→4

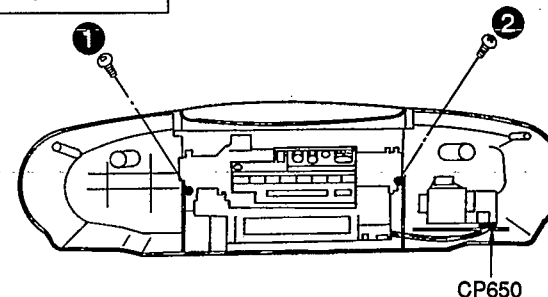

1. Release the connector (CP650).
2. Remove 2 screws (1, 2).

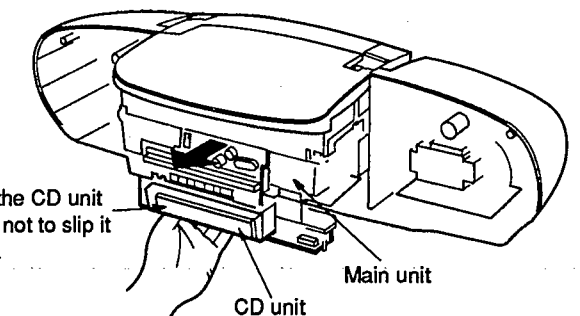

Note:
Hold the CD unit so as not to slip it down.

3. Since the CD unit is not mounted on the main unit, be sure to hold the CD unit so as not to slip it down and remove it from rear cabinet as shown above.

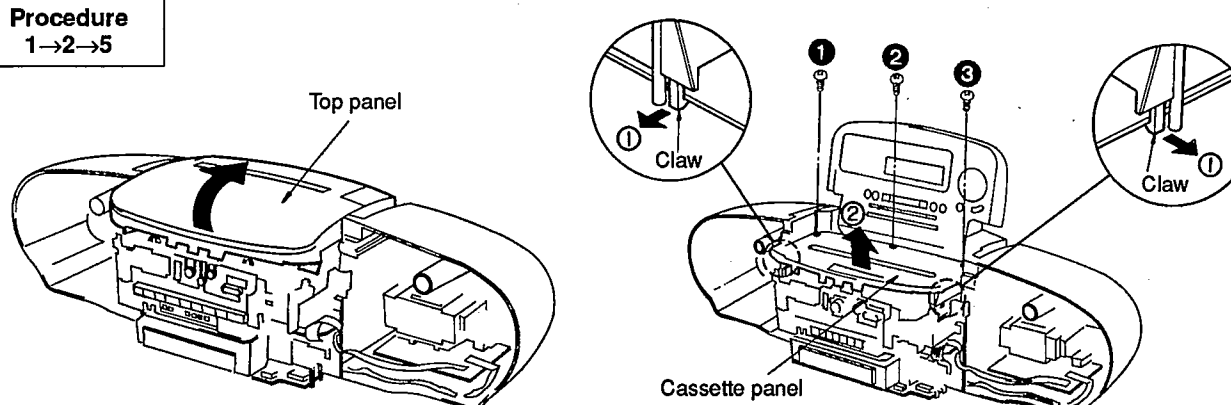
Ref. No. 5	Removal of the Cassette Panel
Procedure 1→2→5	 <p>1. Open the top panel.</p> <p>2. Remove 3 screws (1~3).</p> <p>3. Release 2 claws in the direction of arrow ①.</p> <p>4. Remove the cassette panel in the direction of arrow ②.</p>

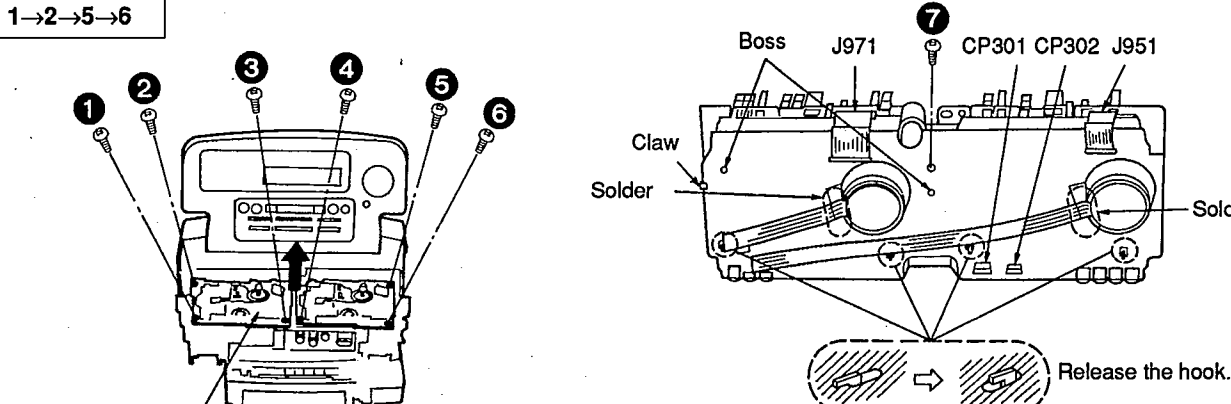
Ref. No. 6	Removal of the Mechanism Unit
Procedure 1→2→5→6	 <p>1. Remove 6 screws (1~6).</p> <p>2. Remove the mechanism unit.</p> <p>3. Release 4 connectors (J951, J971, CP301, CP302).</p> <p>4. Resolder 2 solders.</p> <p>5. Remove the screw (7).</p> <p>6. Release the claw.</p> <p>7. Release 2 bosses.</p> <p>8. Release 4 hooks.</p>

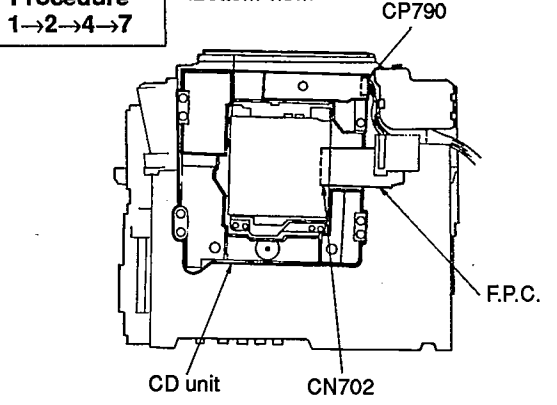
Ref. No. 7	Removal of the CD Unit
Procedure 1→2→4→7	<p><Bottom view></p>  <p>1. Release the connector (CP790).</p> <p>2. Release the connector (CN702).</p> <p>3. Remove the CD unit.</p> <p>9. Remove 2 screws (8, 9).</p>

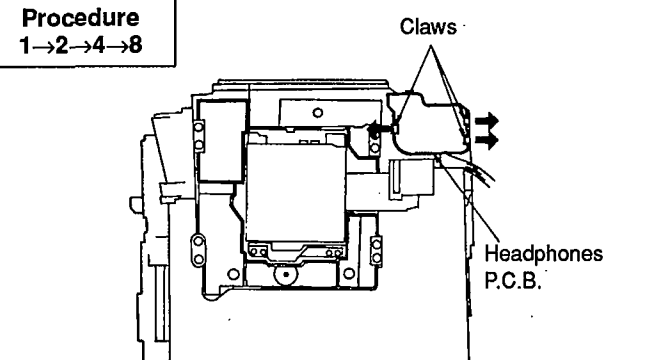
Ref. No. 8	Removal of the Headphones P.C.B.
Procedure 1→2→4→8	 <p>• Release 3 claws in the direction of arrows.</p>

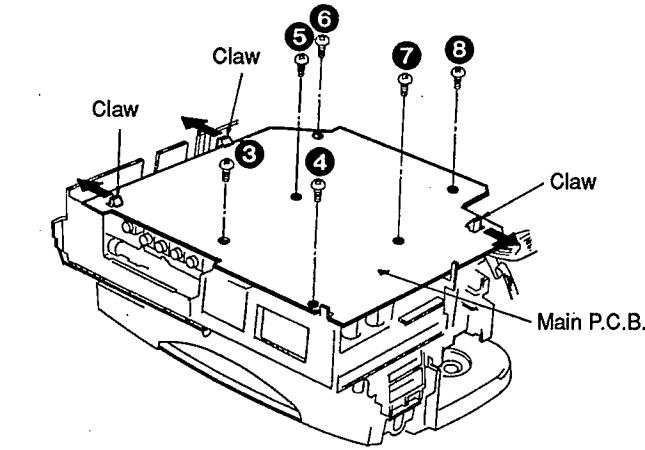
Ref. No. 9	Removal of the Main P.C.B.
Procedure 1→2→4→5→6→7→8→9	 <p>1. Release 3 connectors (CS4601, CS8001, CS8011).</p> <p>2. Remove 2 screws (1, 2).</p> <p>3. Remove the CD unit holder.</p> <p>4. Remove 6 screws (3~8).</p> <p>5. Release 3 claws in the direction of arrows.</p>

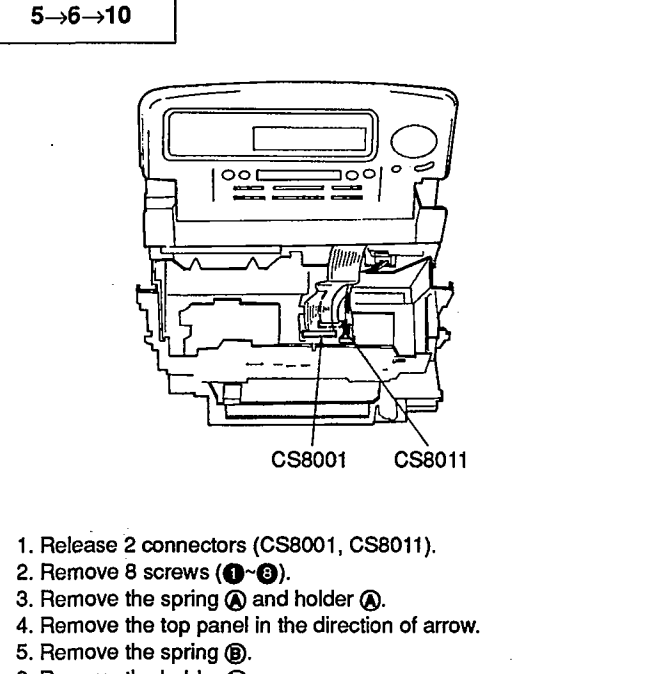
Ref. No. 10	Removal of the Top Panel
Procedure 1→2→4→5→6→10	 <p>1. Release 2 connectors (CS8001, CS8011).</p> <p>2. Remove 8 screws (1~8).</p> <p>3. Remove the spring (A) and holder (A).</p> <p>4. Remove the top panel in the direction of arrow.</p> <p>5. Remove the spring (B).</p> <p>6. Remove the holder (B).</p> <p>7. Remove the lock lever.</p>

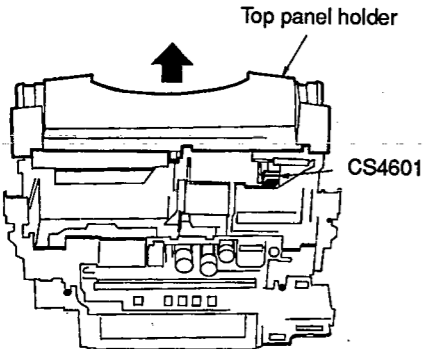
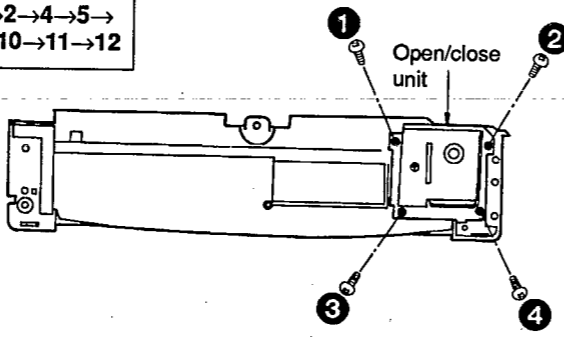
Ref. No. 11	Removal of the Top Panel Holder	Ref. No. 12	Removal of the Open/Close Unit
Procedure 1→2→4→ 5→6→10→11	 <p>1. Release the connector (CS4601). 2. Remove the top panel holder in the direction of arrow.</p>	Procedure 1→2→4→5→ 6→10→11→12	 <p>• Remove 4 screws (1~4).</p>

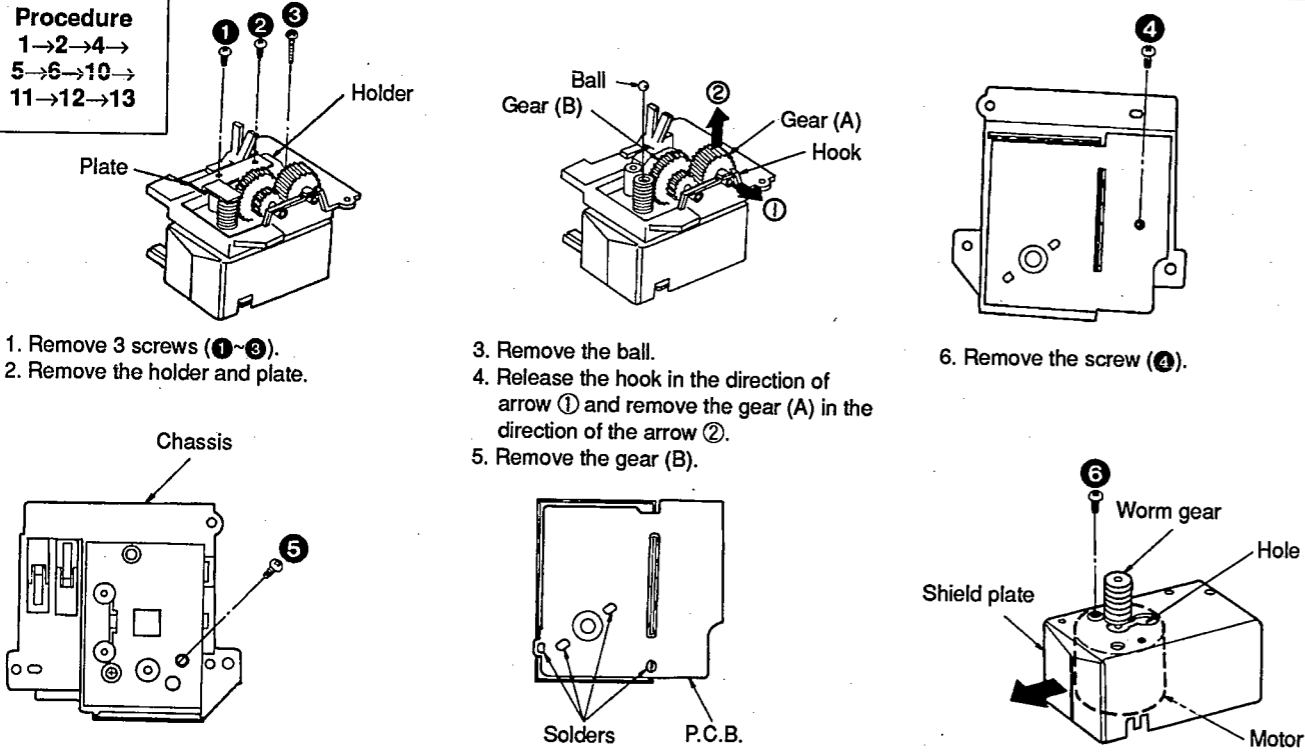
Ref. No. 13	Disassemble of the Open/Close Unit
Procedure 1→2→4→ 5→6→10→ 11→12→13	 <p>1. Remove 3 screws (1~3). 2. Remove the holder and plate. 3. Remove the ball. 4. Release the hook in the direction of arrow ① and remove the gear (A) in the direction of the arrow ②. 5. Remove the gear (B). 6. Remove the screw (4). 7. Remove the screw (5). 8. Remove the chassis. 9. Resolder 4 solders. 10. Remove the P.C.B. 11. Remove the screw (6). 12. Remove the shield plate in the direction of the arrow ③.</p>

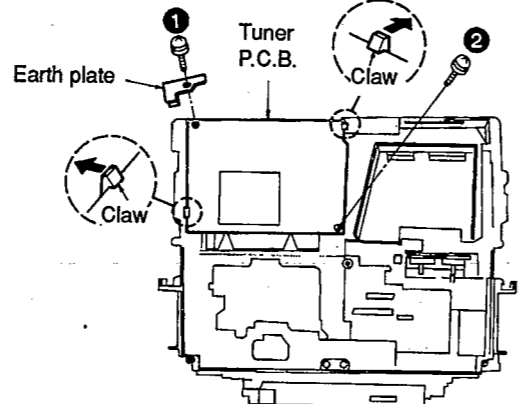
Ref. No. 14	Removal of the Tuner P.C.B.
Procedure 1→2→4→5→ 6→10→11→14	 <p>1. Remove 2 screws (1, 2). 2. Remove the earth plate. 3. Release 2 claws in the direction of arrow.</p>

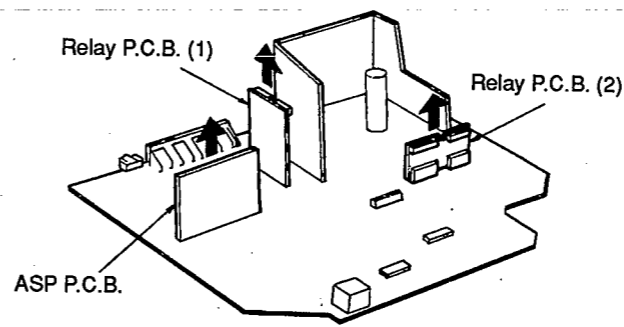
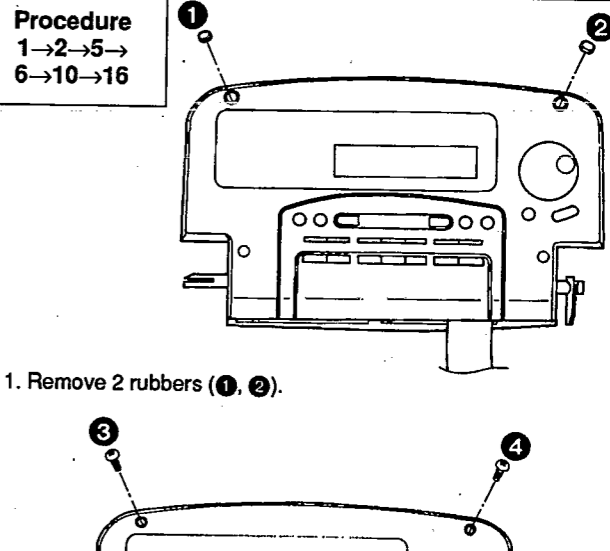
Ref. No. 15	Removal of the ASP P.C.B. and Relay P.C.B.	Ref. No. 16	Removal of the Display Panel
Procedure 1→2→4→ 7→8→9→15	 <p>• Pull out 3 P.C.B.s in the direction of the arrow.</p>	Procedure 1→2→5→ 6→10→16	 <p>1. Remove 2 rubbers (1, 2). 2. Remove 4 screws (3~6). 3. Press the claw in the direction of arrow ① and then remove the display panel in the direction of arrow ②. 4. Slide the display panel in the direction of arrow ③.</p>

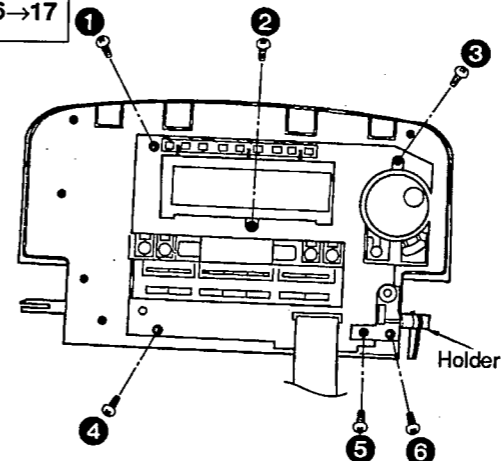
Ref. No. 17	Removal of the LCD P.C.B.
Procedure 1→2→5→ 6→10→16→17	 <p>1. Remove 6 screws (1~6). 2. Remove the holder.</p>

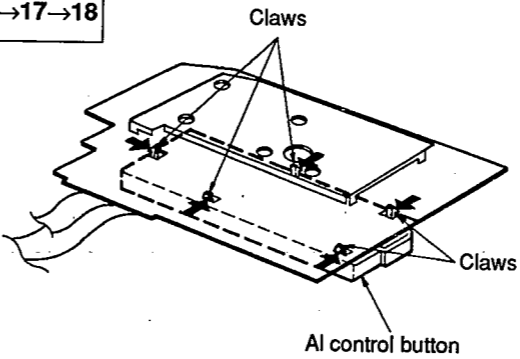
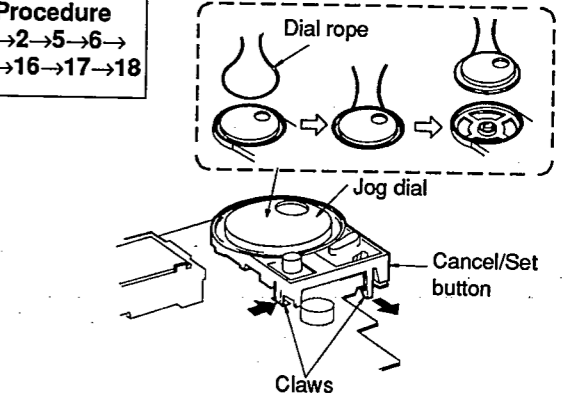
Ref. No. 18	Removal of the AL Control Button	Ref. No. 19	Removal of the AL Jog Dial and Cancel/Set Button
Procedure 1→2→5→6→ 10→16→17→18	 <p>• Release 5 claws in the direction of arrows.</p>	Procedure 1→2→5→6→ 10→16→17→18	 <p>1. Remove the jog dial. 2. Release 2 claws in the direction of arrows.</p>

Ref. No. 20	Removal of the Disc Clamper		
Procedure 1→2→4 →7→20	<p>● Disassembly of the disc clamper</p> <p>1. Release 3 claws in the direction of arrows. 2. Disassemble the disc clamper as shown above.</p>		
<p>● Remove 3 screws (1~3).</p>			

Ref. No. 21	Removal of the Disc Tray		
Procedure 1→2→4 7→20→21	<p>1. Slide the lever fully in the direction of arrow ①. (The traverse unit goes down.)</p> <p>2. Move the disc tray slightly in the direction of arrow ② and unfasten the claw and the rib. 3. Remove 2 screws (1, 2).</p>		

<p>4. Lift the disc tray in the direction of arrow ③. 5. Unfasten the rib from the claw of the chassis.</p>		<p>6. Remove the screw (3). 7. Remove the slider and the shaft.</p>	
---	--	---	--

Ref. No. 22	Removal of the CD P.C.B.	<p>● Removal of the flexible cable Slide the top of the connector in the direction of the arrow ① and disconnect the flexible cable in the direction of the arrow ②.</p>	
Procedure 1→2→4 →7→22	<p>4. Remove the flexible cable (CN701).</p> <p>Note: Insert a short pin into the flexible cable for traverse unit.</p>		
<p>1. Remove the 3 screws (1~3). 2. Unsolder the 2 terminals of spindle motor. 3. Unsolder the 2 terminals of traverse motor.</p>			

Ref. No. 23	Removal of the Loading Motor P.C.B. and Loading Motor	<p>● Removal of the flexible cable Slide the top of the connector in the direction of the arrow ① and disconnect the flexible cable in the direction of the arrow ②.</p>	
Procedure 1→2→4→7 →20→21→23	<p>1. Remove the belt. 2. Remove the 2 screws (1, 2).</p> <p>3. Remove the screw (3). 4. Unsolder the 2 terminals of loading motor.</p>		

Ref. No. 24	Removal of the Traverse Unit		
Procedure 1→2→4→7 →22→24	<p>1. Widen 3 bosses by using a screwdriver and remove 3 pins.</p> <p>2. Release the claw and then remove the traverse unit in the direction of arrow.</p>		

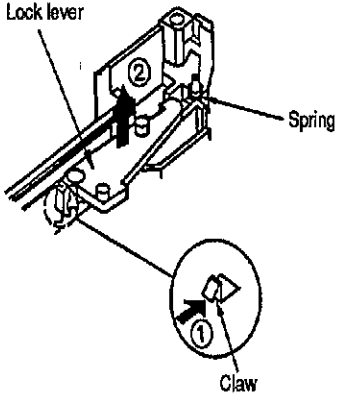
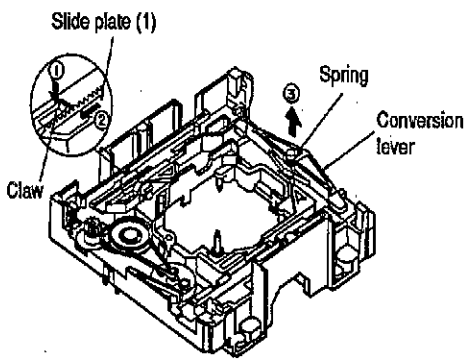
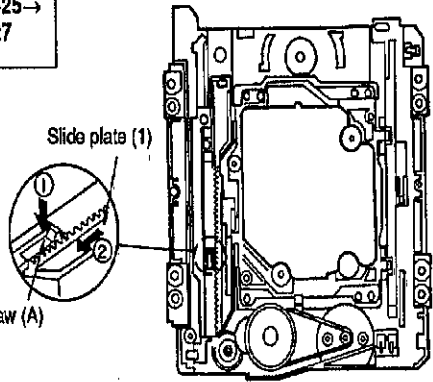
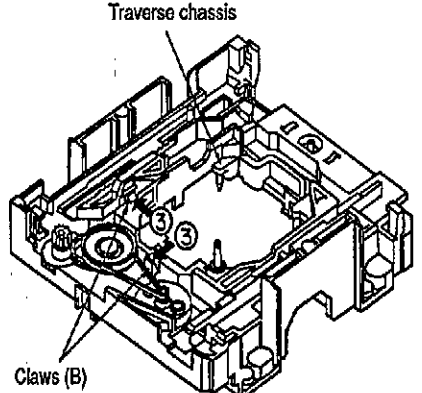
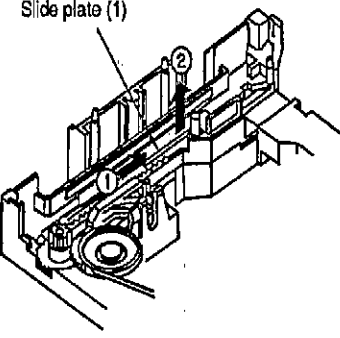
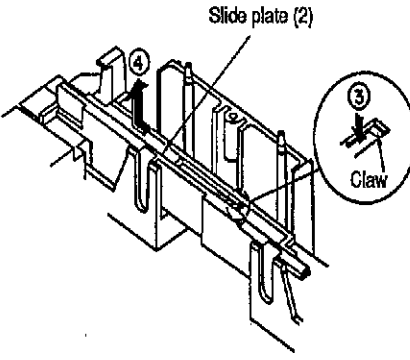
Ref. No. 25	Removal of the Lock Lever	Ref. No. 26	Removal of the Conversion Lever
Procedure 1→2→4→7→ 22→24→25	 <p>1. Remove the spring. 2. Release the claw in the direction of the arrow ①, and then remove the lock lever in the direction of arrow ②.</p>	Procedure 1→2→4→7→ 22→24→25→26	<ol style="list-style-type: none"> 1. Remove the spring. 2. Push the claw in the direction of arrow ①, and then move the slide plate (1) in the direction of arrow ②. 3. Remove the conversion lever in the direction of arrow ③. 
Ref. No. 27	Removal of the Traverse Chassis		
Procedure 1→2→4→7→ 22→24→25→ 26→27	 <p>1. Push the claw (A) in the direction of arrow ①, and then move the slide plate (1) in the direction of arrow ②.</p>	 <p>2. Push 2 claws (B) in the direction of arrow ③, and then remove the traverse chassis.</p>	
Ref. No. 28	Removal of the Slide Plate (1) and Slide Plate (2)		
Procedure 1→2→4→7→ 22→24→25→ 26→27→28	 <p>■ Removal of the Slide Plate (1)</p> <p>• Move the slide plate (1) in the direction of the arrow ①, and remove the slide plate (1) in the direction of the arrow ②.</p>	 <p>■ Removal of the Slide Plate (2)</p> <p>• Push the claw in the direction of the arrow ③, and remove the slide plate (2) in the direction of the arrow ④.</p>	

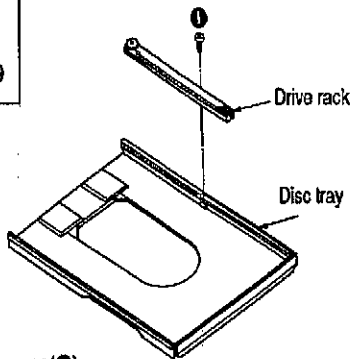
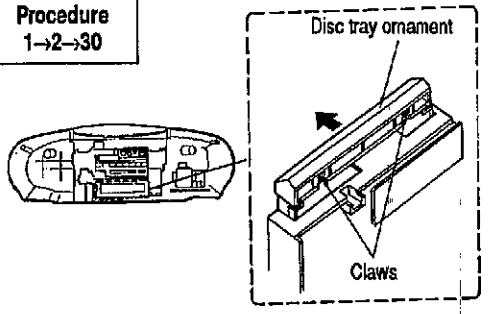
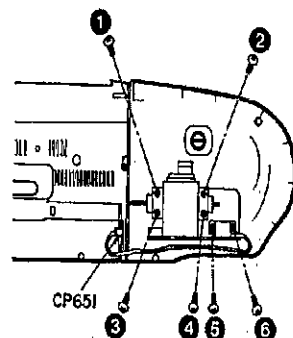
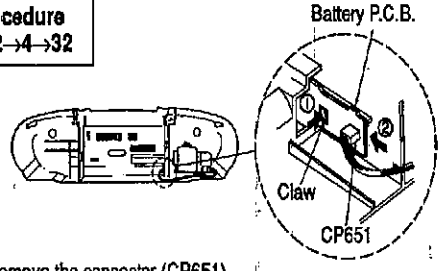
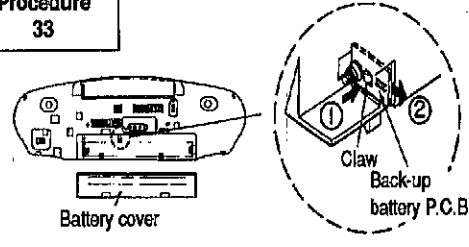
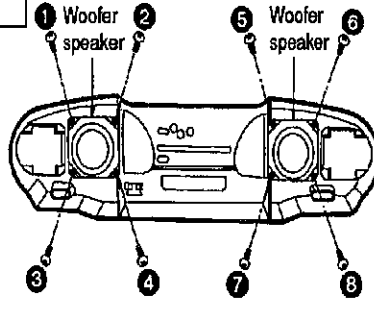
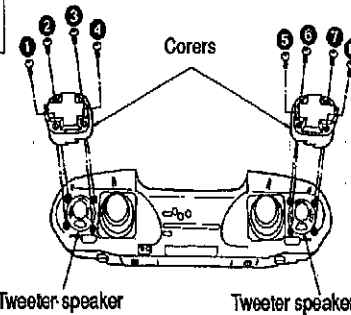
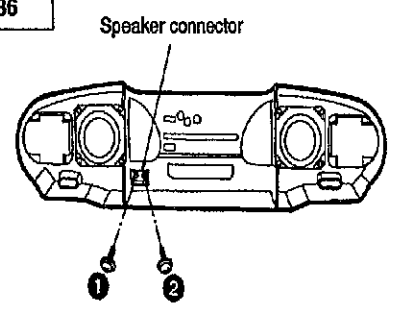
Ref. No. 29	Removal of the Drive Rack	Ref. No. 30	Removal of the Disc Tray Ornament
Procedure 1→2→4→7→ 20→21→29	 <p>• Remove the screw (1).</p>	Procedure 1→2→30	 <p>• Remove the disc tray in the direction of arrow by keeping the 2 claws pressed.</p>
Ref. No. 31	Removal of the Power P.C.B.	Ref. No. 32	Removal of the Battery P.C.B.
Procedure 1→2→4→31	<ol style="list-style-type: none"> 1. Release the connector (CP651). 2. Remove 6 screws (1~6). 	Procedure 1→2→4→32	 <ol style="list-style-type: none"> 1. Remove the connector (CP651). 2. Remove the battery P.C.B. in the direction of arrow ② by keeping the claw pressed in the direction of arrow ①.
Ref. No. 33	Removal of the Back-up Battery P.C.B.	Ref. No. 34	Removal of the Woofer Speaker
Procedure 33	 <ol style="list-style-type: none"> 1. Remove the battery cover. 2. Remove the back-up battery P.C.B. in the direction of arrow ② by keeping the claw pressed in the direction of arrow ①. 	Procedure 1→2→34	 <p>• Remove 8 screws (1~8).</p>
Ref. No. 35	Removal of the Tweeter Speaker	Ref. No. 36	Removal of the Speaker Connector
Procedure 1→2→35	 <ol style="list-style-type: none"> 1. Remove 8 screws (1~8). 2. Remove 2 covers. 	Procedure 1→2→36	 <p>• Remove 2 screws (1, 2).</p>

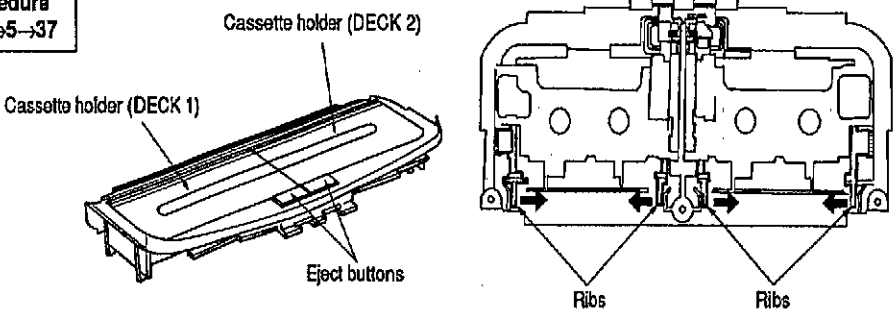
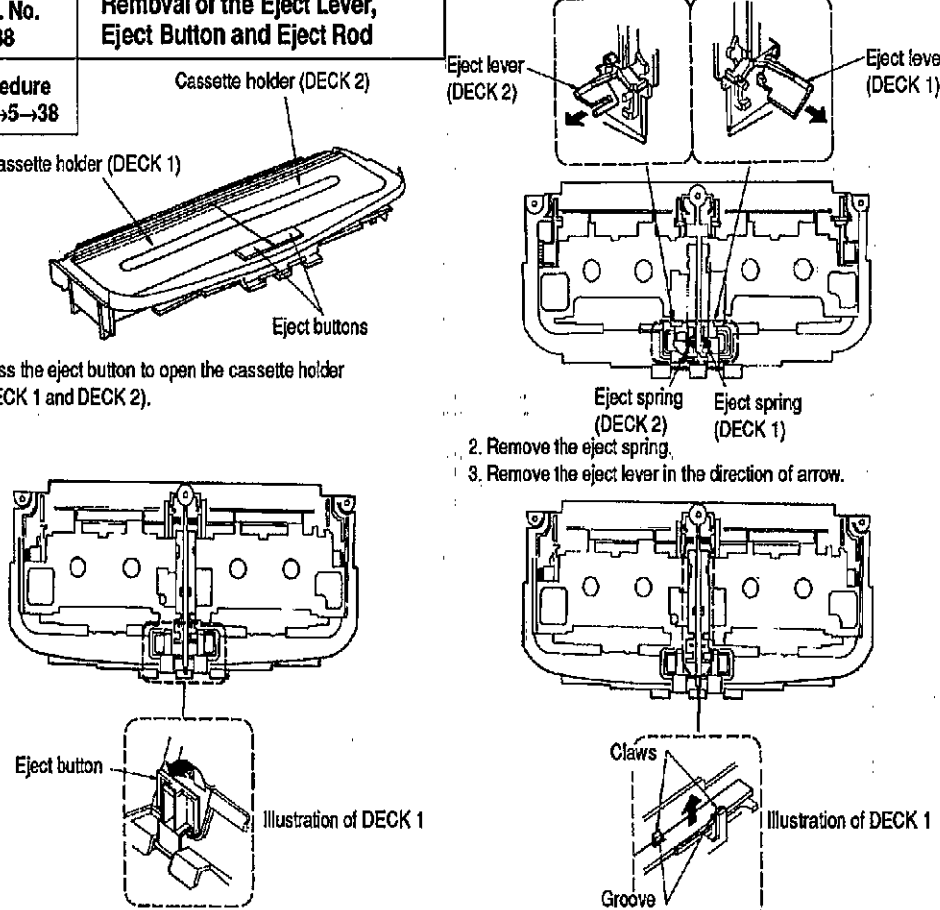
Ref. No. 37	Removal of the Cassette Holder		
Procedure 1→2→5→37			
	1. Press the eject button and then open the cassette holder	2. Remove the cassette holder by keeping the 4 ribs pressed in the direction of arrow.	
Ref. No. 38	Removal of the Eject Lever, Eject Button and Eject Rod		
Procedure 1→2→5→38			
	1. Press the eject button to open the cassette holder (DECK 1 and DECK 2).	2. Remove the eject spring.	3. Remove the eject lever in the direction of arrow.
	4. Remove the eject button in the direction of arrow.	5. Fit 2 claws into the groove of the eject rod.	6. Remove the eject rod in the direction of arrow.

NOTE:
Please refer to pages 10-13 in the service manual for Model No. SL-CH550 (Order No. AD9208264C8) for information on "INSTALLING SERVO (CD) P.C.B.", "INSTALLING OF GUIDE SHAFT", "CD UNIT ASSEMBLY", "INSTALLING DISC TRAY UNIT" and "INSTALLING DISC TRAY".

●INSTALLATION OF CASSETTE HOLDER

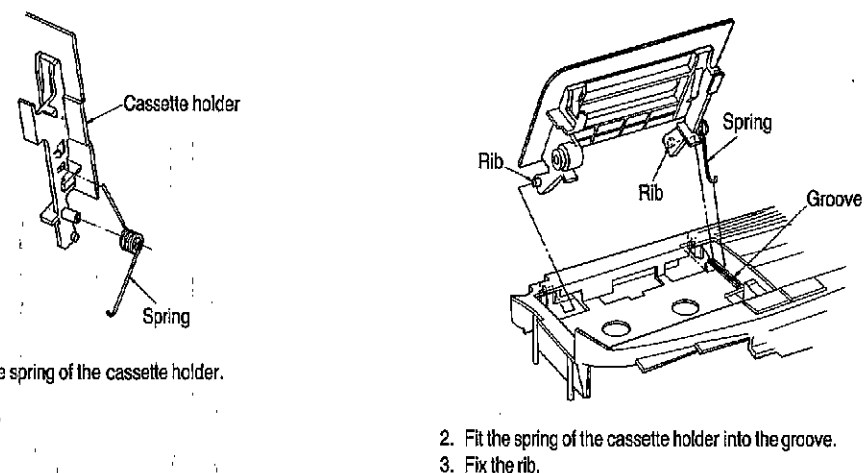

1. Install the spring of the cassette holder.

2. Fit the spring of the cassette holder into the groove.
3. Fix the rib.

●INSTALLATION OF MECHANISM UNIT

●Install the mechanism unit by connecting the connectors correctly.

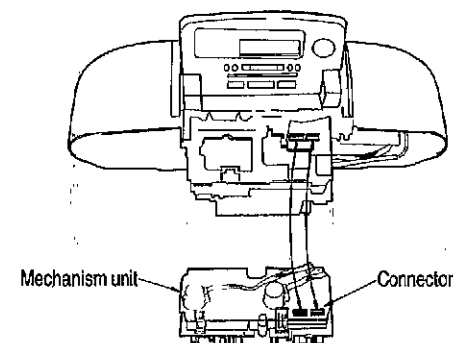

●INSTALLATION OF FRONT PANEL

●Install the front panel by connecting the speaker connector correctly.

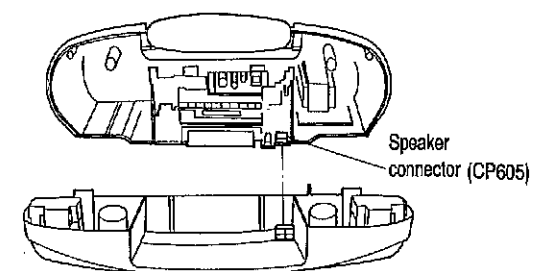

●MEASURE FOR TAPE TROUBLE

If a cassette tape cannot be removed from the deck since the tape is caught by the capstan or pinch roller during playback or recording, rotate the pulley in the direction of the arrow to remove the tape.

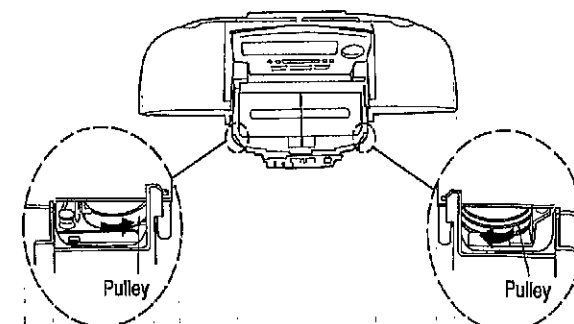

SCHEMATIC DIAGRAM • TUNER AND CD CIRCUIT (Parts list on pages 69~77.)

A TUNER CIRCUIT

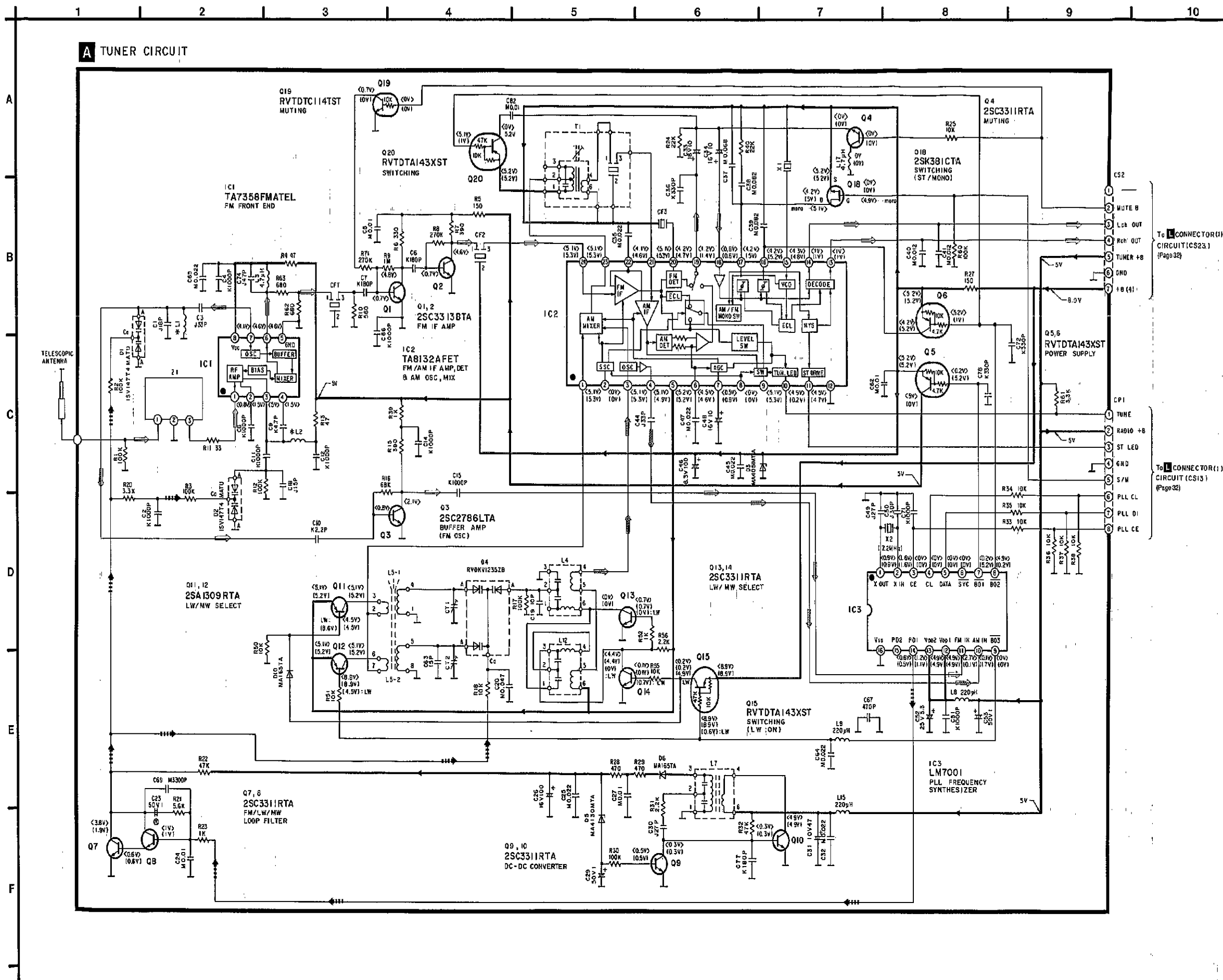

11

12

13

14

15

16

17

18

19

B CD CIRCUIT

OPTICAL PICK UP CIRCUIT

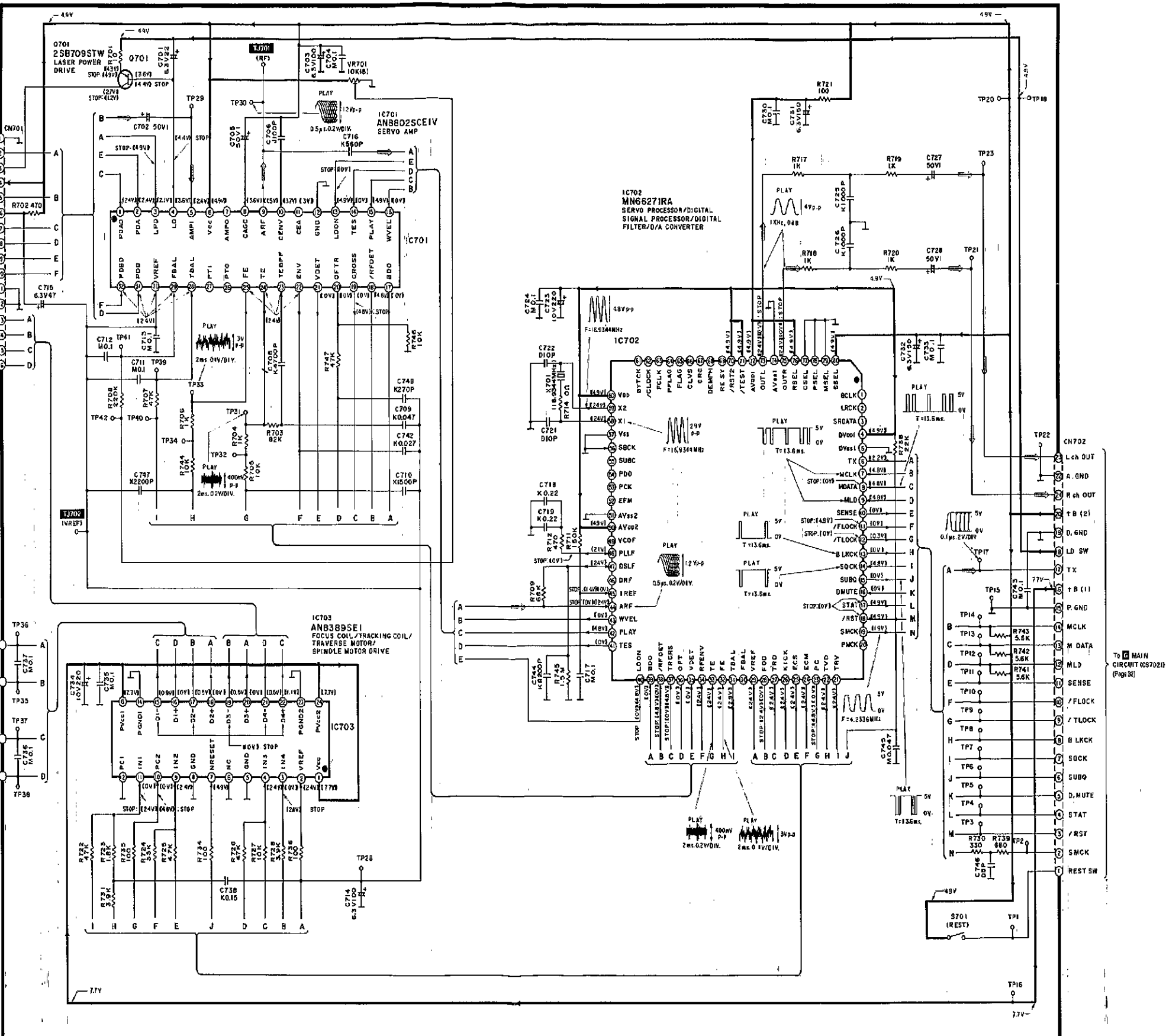
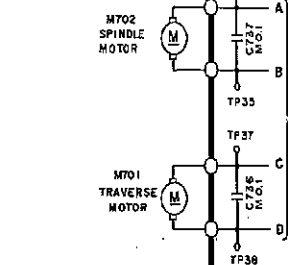
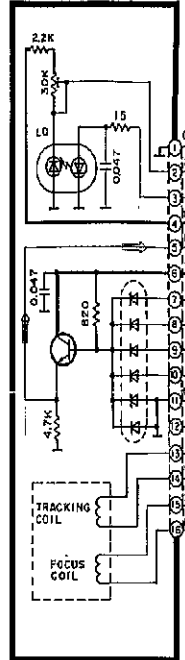

6

7

8

9

10

11

12

13

14

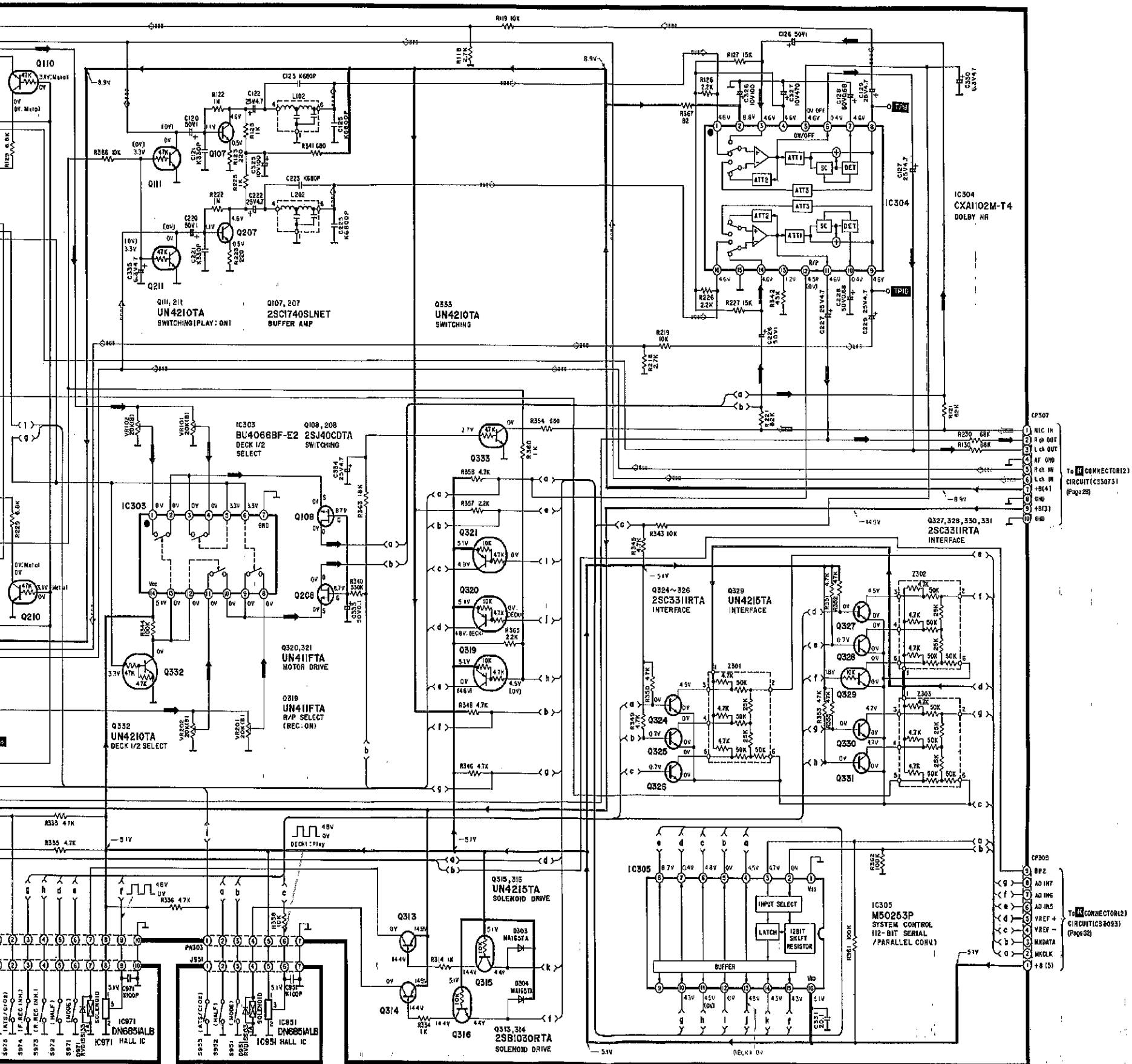

MECHANISM (DECK2) CIRCUIT

MECHANISM (DECK1) CIRCUIT

SCHEMATIC DIAGRAM • MAIN, CONNECTOR, PANEL OPEN/CLOSE, ASP, LOADING MOTOR

Notes:

<for Main circuit>

- S650 : AC/DC select switch.
- S681 : Disc tray open/close switch (CD OPEN/CLOSE)
- S682 : Top panel open/close switch. (OPEN/CLOSE)
- S683 : Volume up switch. (VOL +)
- S684 : Volume down switch. (VOL -)
- S685 : Operation switch. (OPERATION)
- S686 : CD stop switch. (■)
- S687 : CD playback switch. (▶)
- S688 : Function select switch. (TUNER/BAND)
- S689 : Deck forward side playback switch. (▶)
- S690 : Deck reverse side playback switch. (◀)
- S691 : Deck stop switch. (■)
- S692 : Deck fast/TPS switch. (TPS▶▶)
- S693 : Deck fast/TPS switch. (◀◀TPS)
- S790 : Disc tray close detect switch.
- S791 : Disc tray open detect switch.
- S4601 : Top panel open detect switch.
- S4602 : Top panel close detect switch.

<LCD circuit>

- S800 : AI jog dial. (AI JOG)
- S801 : Program set switch. (SET)
- S802 : Cancel switch. (CANCEL)
- S803 : Timer/clock switch. (TIMER/CLOCK)
- S804 : Sleep switch. (SLEEP)
- S805 : Timer recording switch. (REC-TIMER)
- S806 : Timer play switch. (PLAY-TIMER)
- S807 : ATLS switch. (ATLS)
- S808 : Recording pause switch. (●■)
- S809 : Auxiliary input select switch. (AUX)
- S810 : Tape counter reset switch. (COUNTER RESET)
- S811 : Reverse mode select switch. (REV MODE)
- S812 : Deck select switch. (DECK1/2)
- S813 : Edit recording switch. (HIGH)
- S814 : Edit recording switch. (NORMAL)
- S815 : T-SURROUND switch. (T-SURROUND)
- S816 : Beep on/off switch. (BEEP)
- S817 : CD edit switch. (CD EDIT)
- S818 : Dolby NR switch. (DOLBY NR)
- S819 : Preset equalizer select switch. (PRESET EQ)
- S823 : S-XBS level control switch. (S-XBS LEVEL)
- S824 : Tuning mode select switch. (TUNING MODE)
- S825 : Title switch. (TITLE)

General

- DC voltage measurements are taken with electronics voltmeter.
- The negative terminal of the battery provides negative meter connection point.

No mark...TAPE PLAYBACK (DECK 2) []...TUNER ([])...CD

[]...AUX

•Battery current:

Vol. min	420 mA (FM)	Vol. max	1010 mA (FM)
	410 mA (LW/MW)		690 mA (LW/MW)
	490 mA (TAPE)		1800 mA (TAPE)
	620 mA (CD)		2140 mA (CD)

Measurement instruction
 LW/MW: 74 dB/m, 30% Mod.
 FM: 60 dB, 30% Mod.
 TAPE: 315 Hz, 0 dB
 CD: 1 kHz, 0 dB

•Important safety notice.

- Components identified by Δ mark have special characteristics important for safety.
- When replacing any of these components, use only manufacturer's specified parts.

•This schematic diagram may be modified at any time with the development of new technology.

 : FM Signal Line

 : CD Signal Line

 : AF Signal Line

 : Recording Signal Line

 : Mic Signal Line

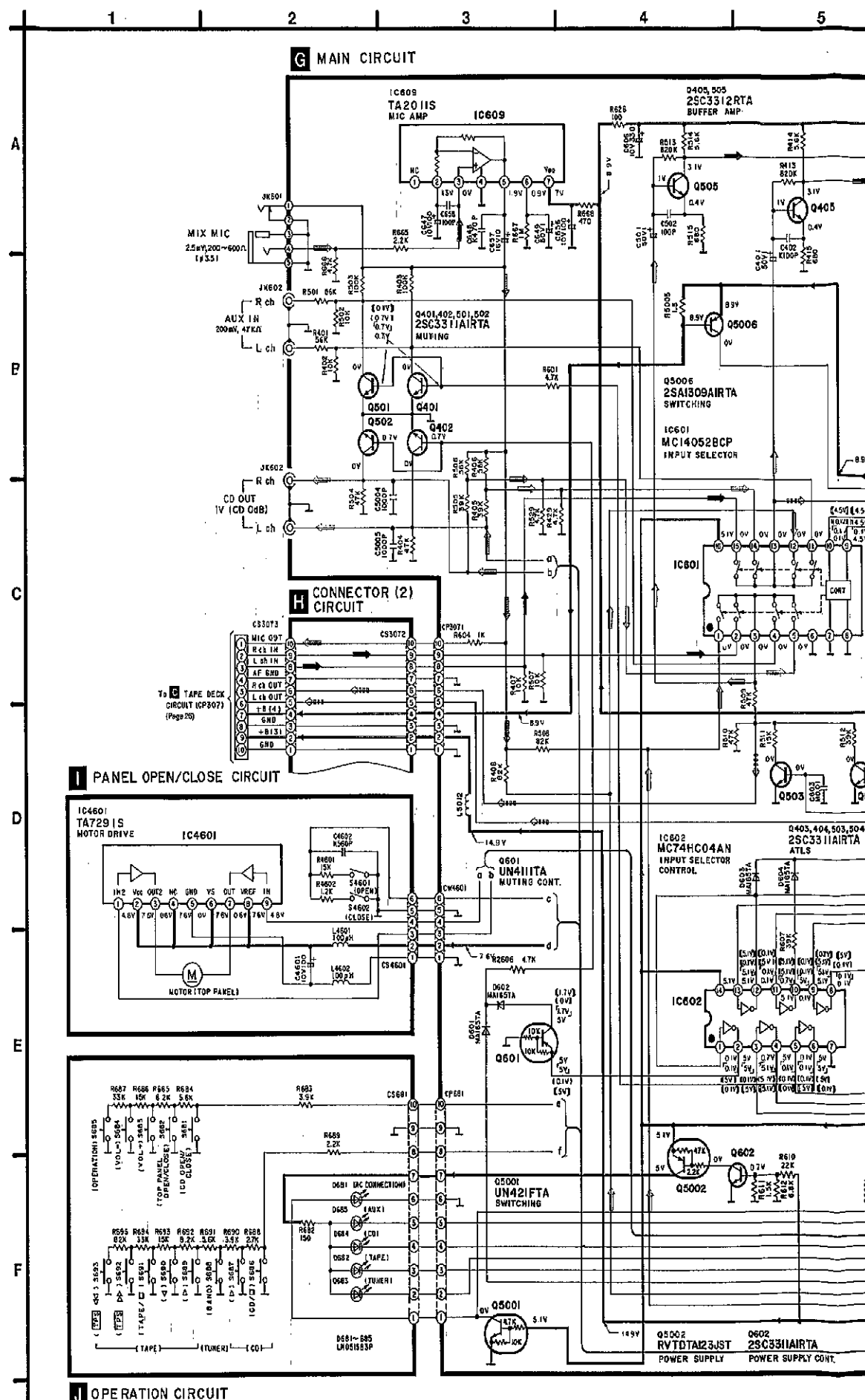
 : +B Line

6 7 8 9 10 11 12 13 14

K ASP CIRCUIT

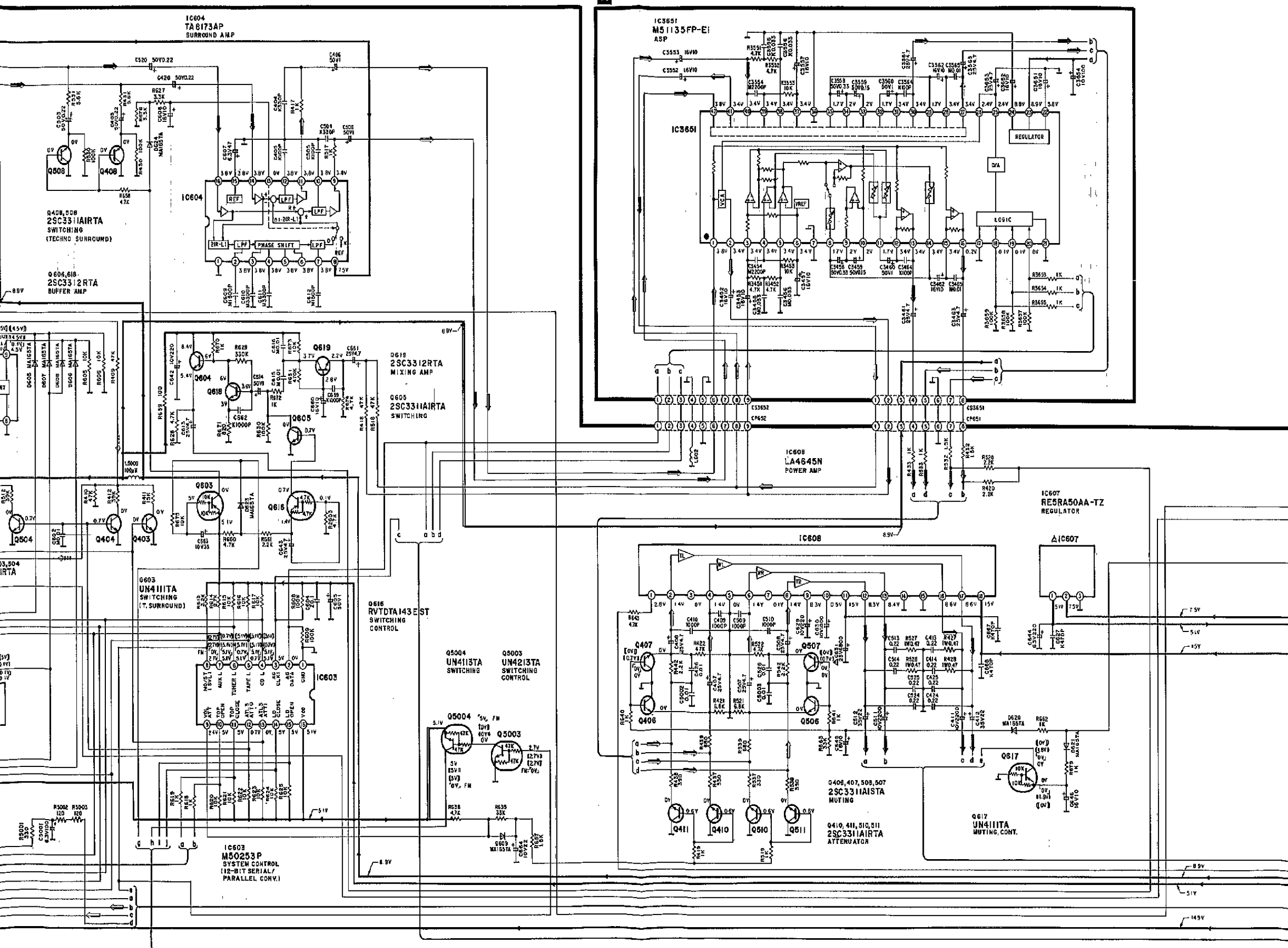

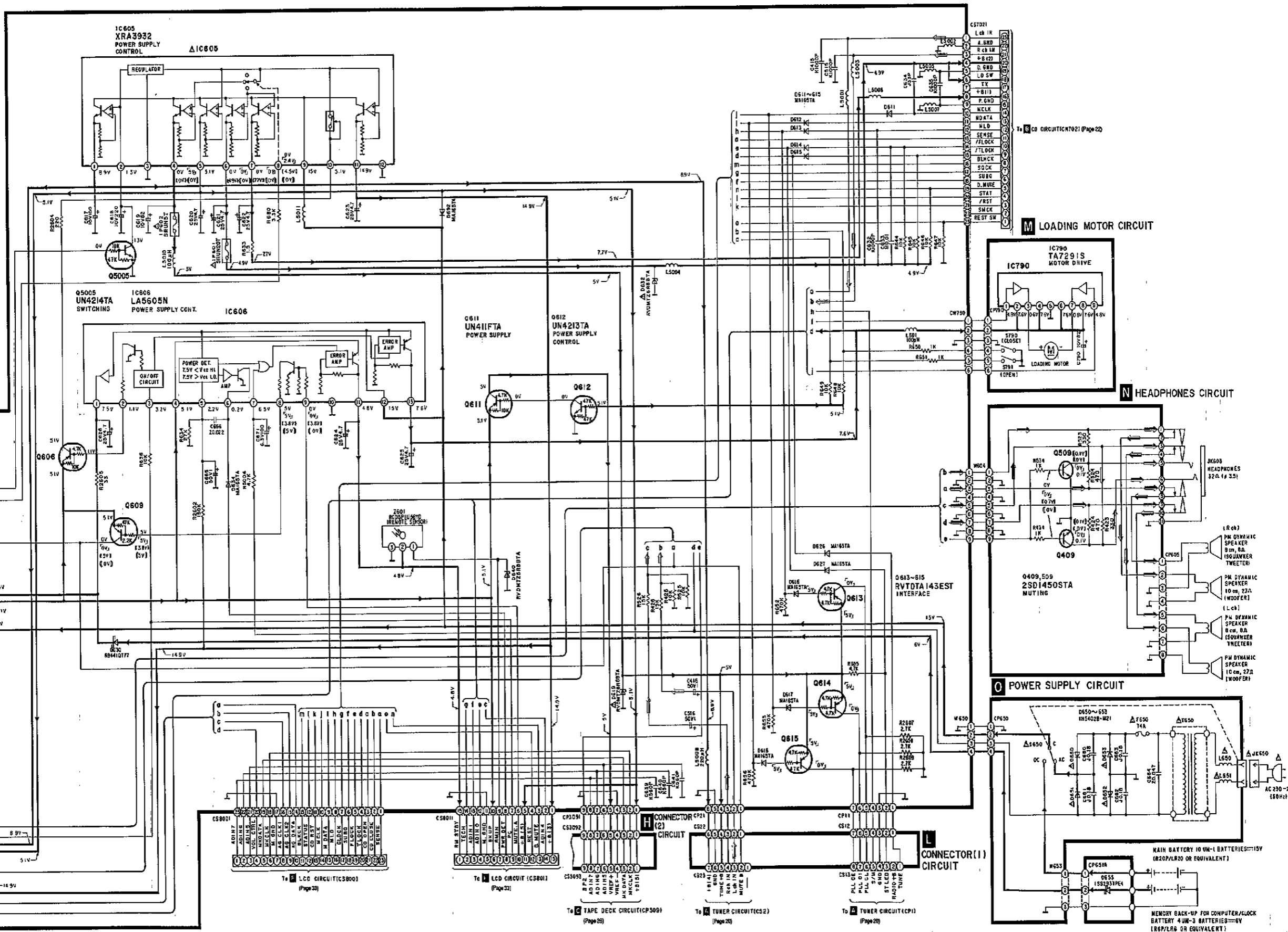

M LOADING MOTOR CIRCUIT

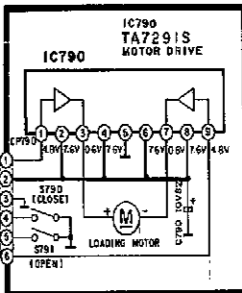

N HEADPHONES CIRCUIT

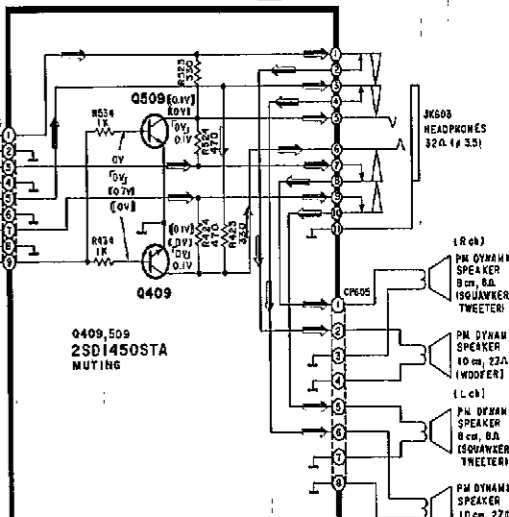

O POWER SUPPLY CIRCUIT

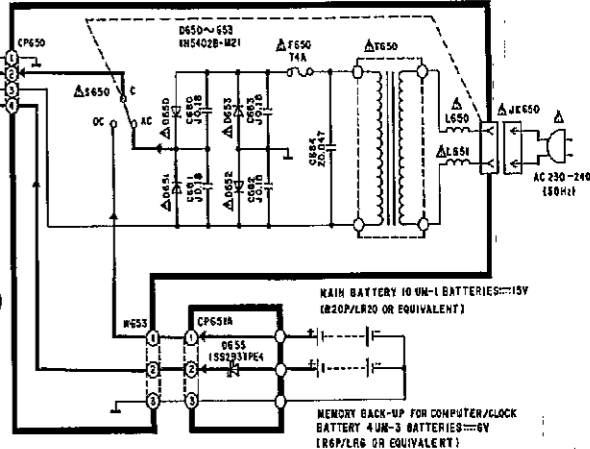

F LCD CIRCUIT

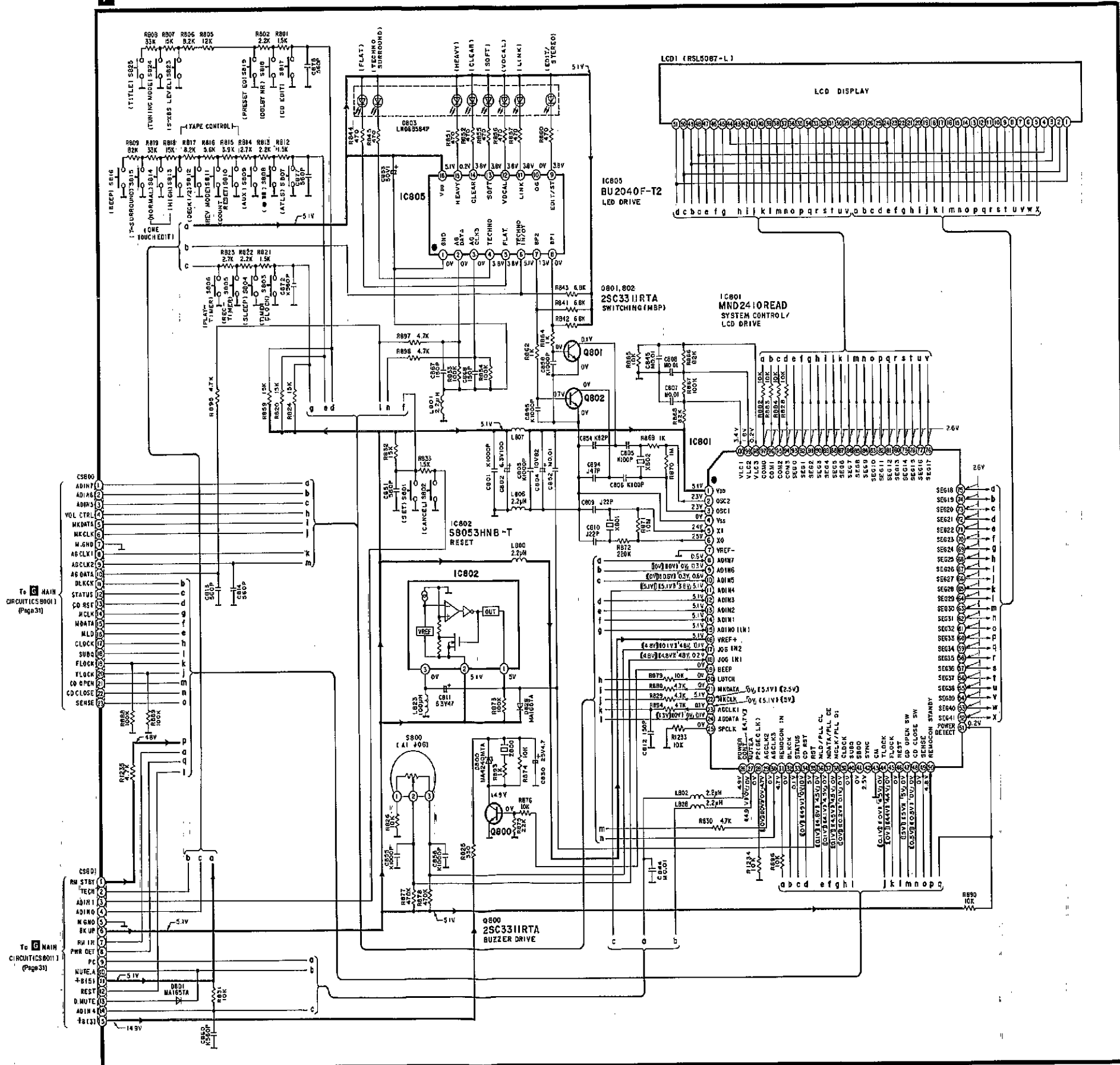

12

13

14

15

16

17

18

19

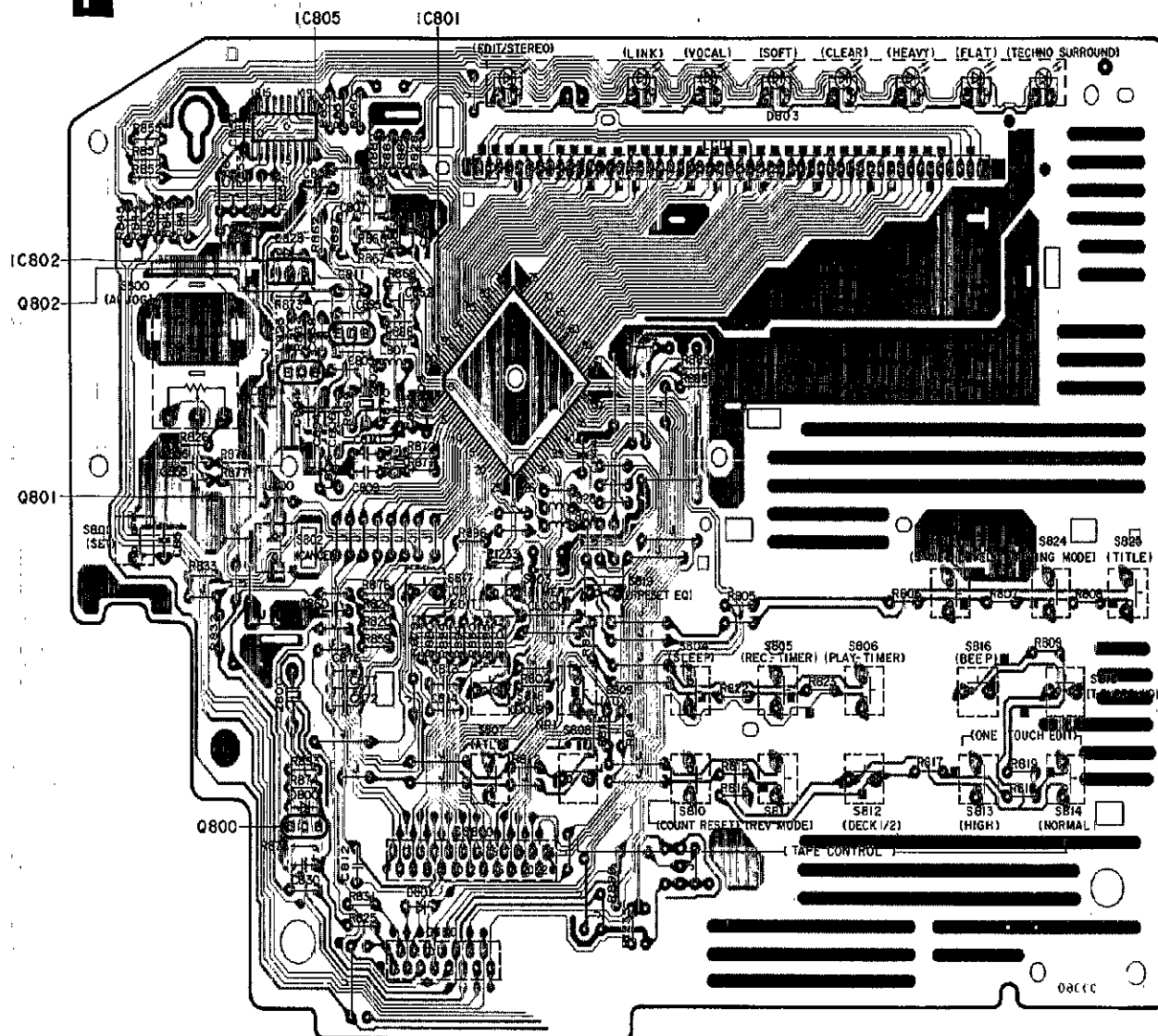
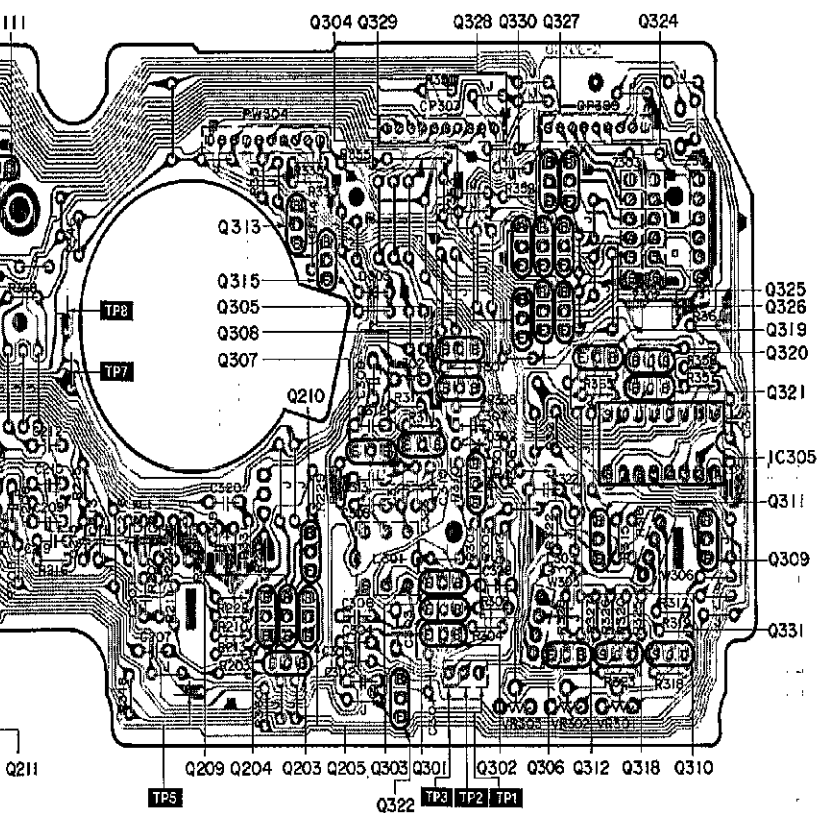
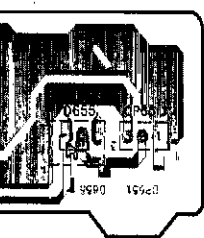
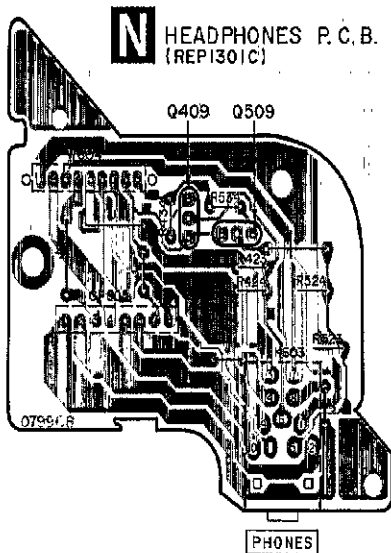
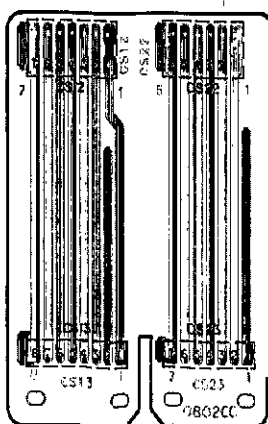
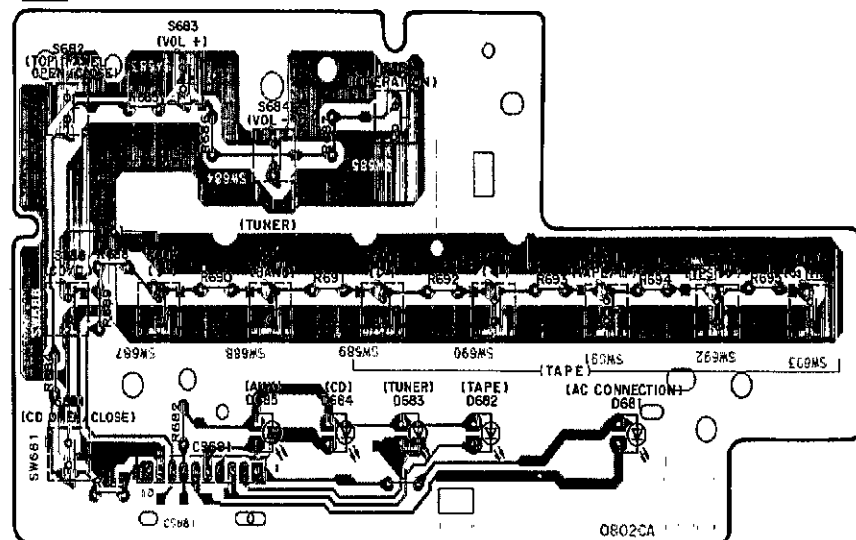
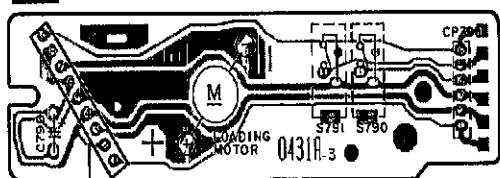
F LCD P.C.B. (REP1302C)**N** HEADPHONES P.C.B. (REP1301C)**L** CONNECTOR (I) P.C.B. (REP1304B)**J** OPERATION P.C.B. (REP1304B)**M** LOADING MOTOR P.C.B. (REP0767)

IC790

WIRING CONNECTION DIAGRAM

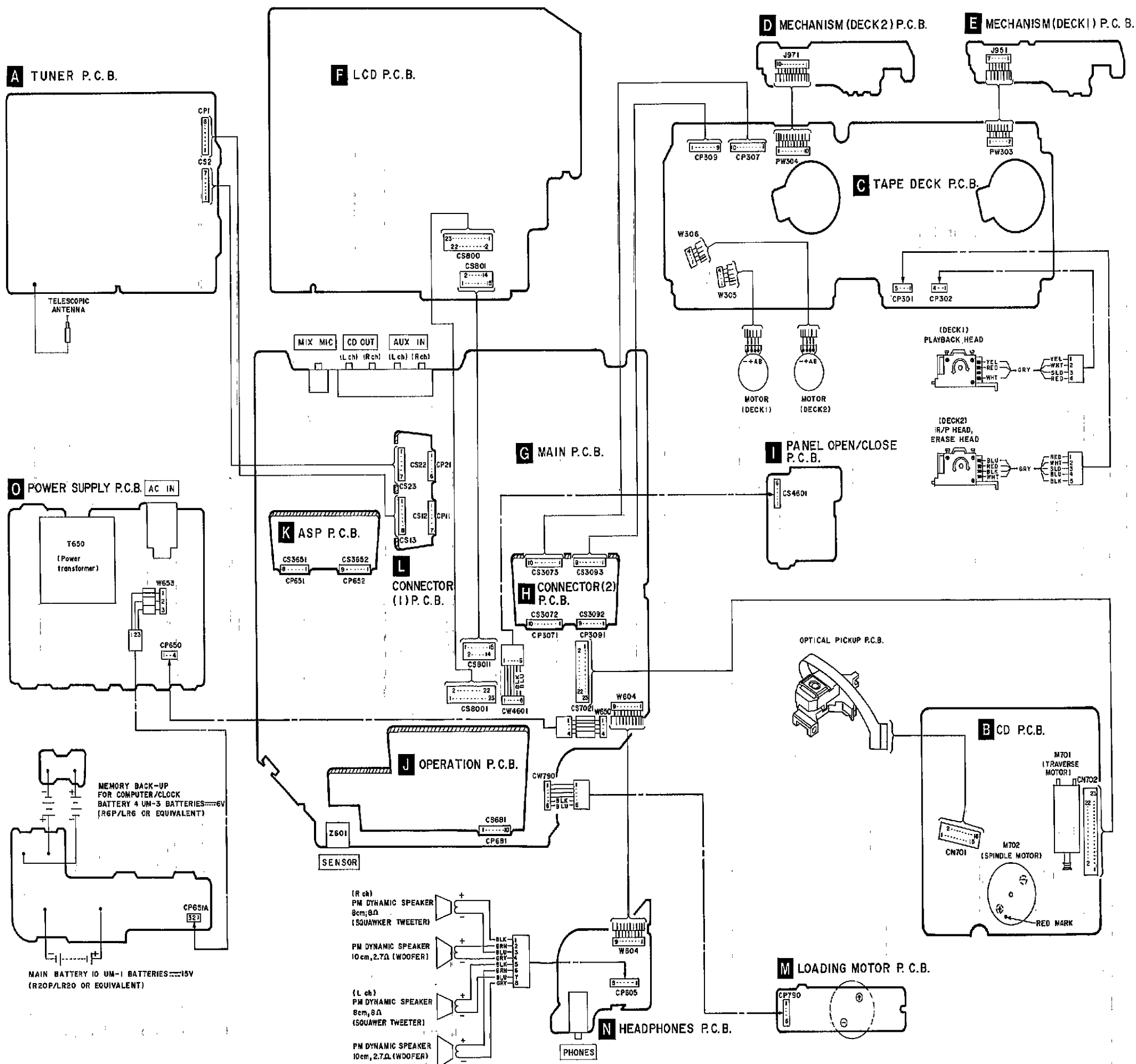

■ PREPARATIONS FOR CHECK AND ADJUSTMENT OF P.C.B.

- Fabricate the measuring instrument as shown below to measure the audio output via the headphones jack for check and adjustment of the P.C.B.

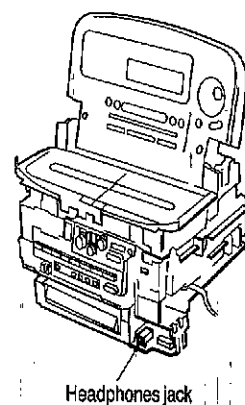
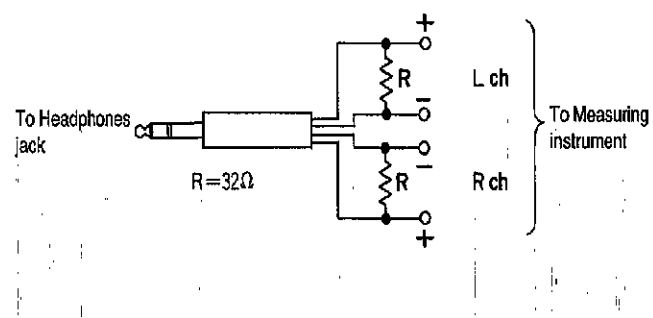

- If you wish to measure the audio output from the speaker without using the measuring instrument (i.e. output from the headphones), make connection in the way shown below.

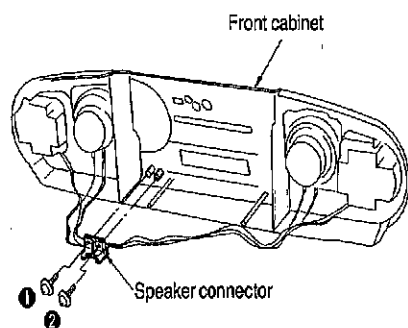

1. Remove 2 screws (1, 2) to remove the speaker connector.
2. Remove the speaker cable from the boss used for wire arrangement.

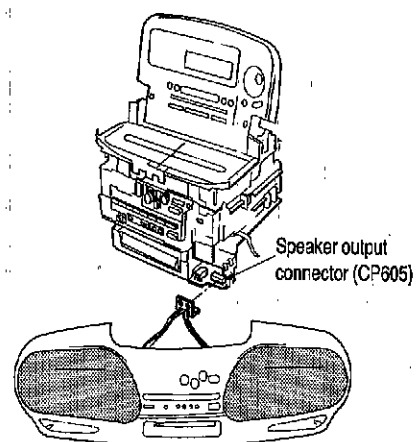

3. Connect the speaker connector with the speaker output connector (CP605).

- Use the extension cable kit as shown below when checking and adjusting the unit's P.C.B.

Part No.: RFKZ0024 (set of 4 extension cables)

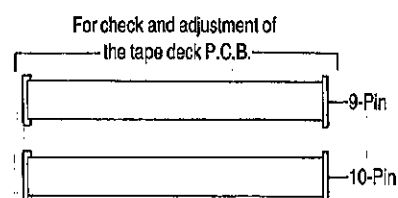
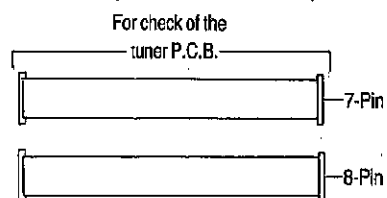

Part No.: RFKZ0099 (set of 2 extension cables)

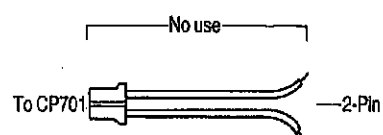
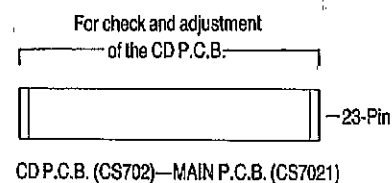

- Check and adjustment of Tuner P.C.B.

1. Follow the disassembly instructions of Ref. No. 4 "Removal of the main unit" to remove the main unit. (Refer to page 8.)

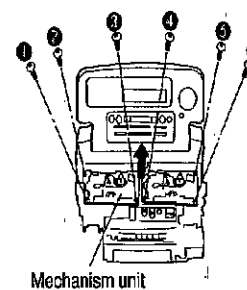

2. Remove 6 screws (1-6).
3. Remove the mechanism unit.

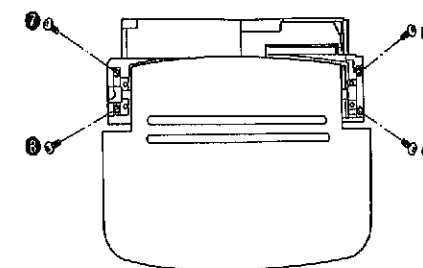

4. Remove 4 screws (7-10).

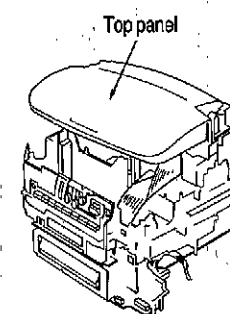

5. Lift up the top panel.

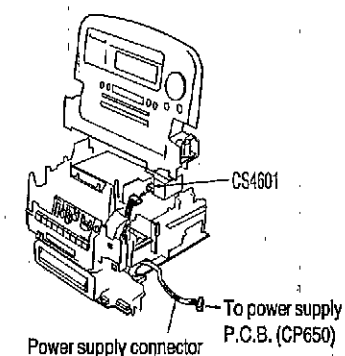

6. Open the top panel.
7. Release the connector (CS4601).
8. Connect the power supply connector for power P.C.B. (CP650).

Be especially careful not to bend or break the FPC.

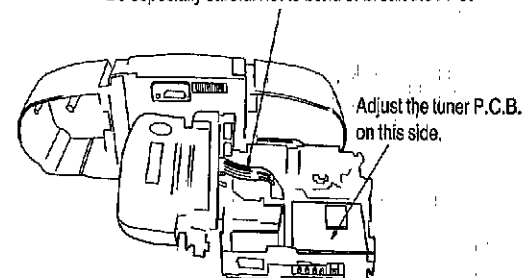

9. Place the main unit and top panel as shown above.

- Check the tuner P.C.B.

10. Remove 2 screws (11-12).
11. Release 2 claws in the direction of arrows.
12. Remove the tuner P.C.B.

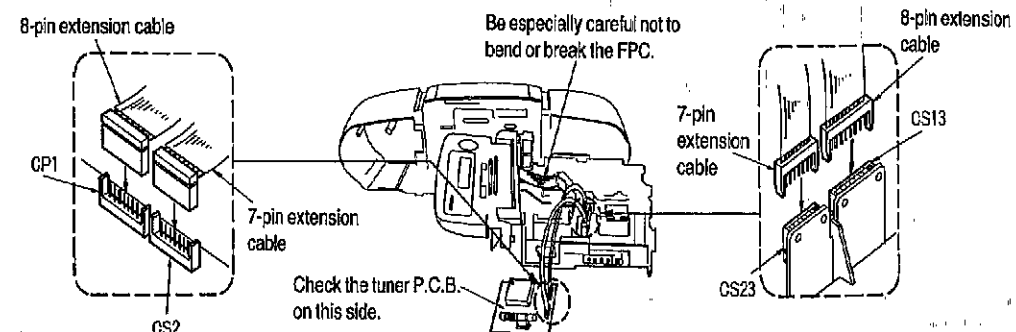
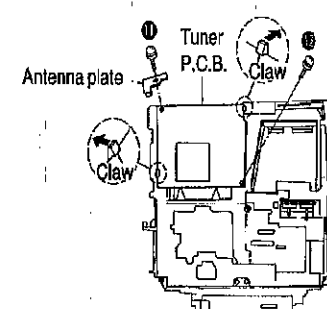

13. Connect the 8-pin connector and 7-pin connector of the extension cable (RFKZ0024).
- Adjustment the tuner P.C.B.

●Check and adjustmet of tape deck P.C.B.

1. Follow the disassembly instructions of Ref. No. 5 "Removal of the cassette panel" to remove the cassette panel. (Refer to page 9.)

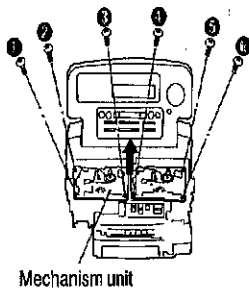

2. Remove 6 screws (1-6).
3. Remove the mechanism unit.

4. Connect the 9-pin connector and 10-pin connector of the extension cable (RFKZ0024).
5. Connect the power supply connector for power supply P.C.B. (CP650).

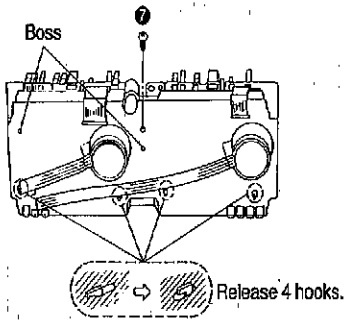

6. Remove the screw (7).
7. Release 2 bosses.
8. Release 4 claws.

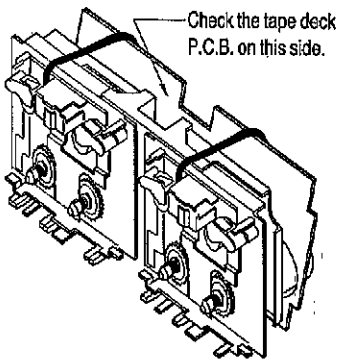

11. Place the tape deck P.C.B. as shown above.
- Be sure to check the tape deck P.C.B. under this condition.

10-pin extension cable CP307 CP309

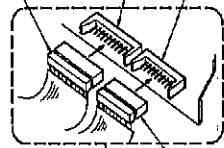

9-pin extension cable

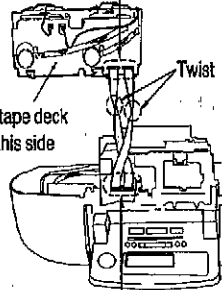

10-pin extension cable

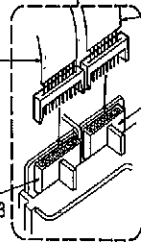

Head lead wire

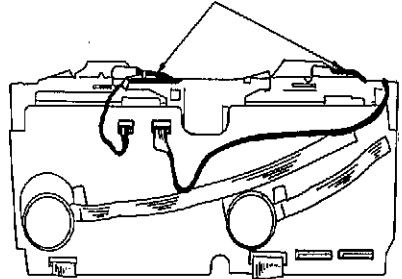

9. Place the tape deck unit as shown above.
10. Release 2 head lead wires from hook.

Check and adjustment of CD P.C.B.

1. Follow the disassembly instructions of Ref. No. 7 "Removal of the CD unit" to remove the CD unit. (Refer to page 9.)

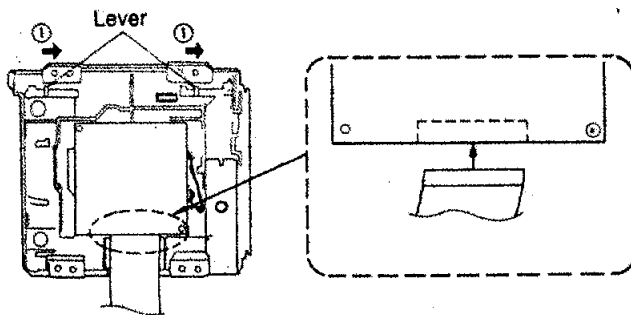
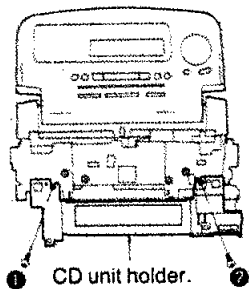

2. Remove 2 screws (1, 2).
3. Remove the CD unit holder.

4. Slide the lever fully in the direction of arrow ① and pull the CD P.C.B. toward you.
5. Connect the extension cable (RFKZ0009) to the CD P.C.B.

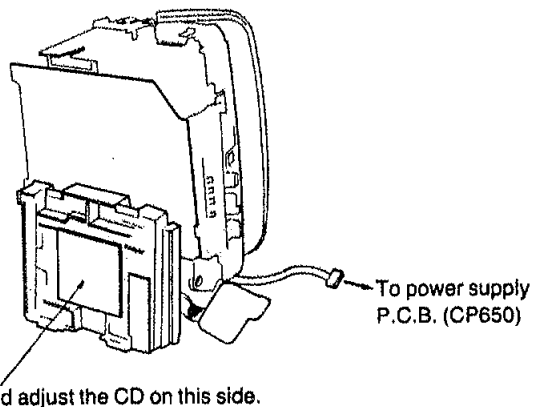
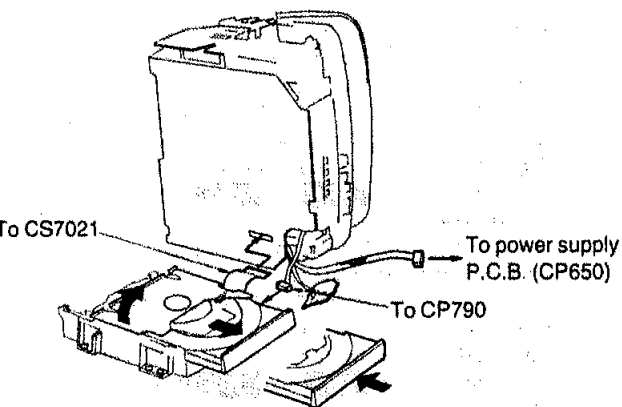

6. Connect the CD unit to the main P.C.B.
7. Connect the power supply connector to the power supply P.C.B. (CP650).
8. Press the CD/□ button.
(Power is turned on and the deck is set to the CD function mode.)
9. Press the CD OPEN/CLOSE button to open the disc tray.
10. Load the test disc into the disc tray and press the CD OPEN/CLOSE button to close the disc tray.

11. Place the CD unit as shown above.
•Be sure to check and adjust the CD P.C.B. under this condition.

Check of electronic volume P.C.B.

1. Follow the disassembly instruction of Ref. No. 4 "Removal of the main unit" to remove the main unit. (Refer to page 8.)

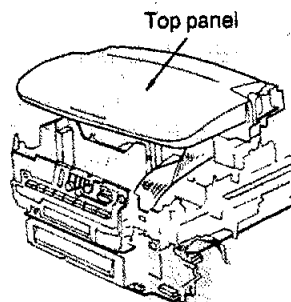
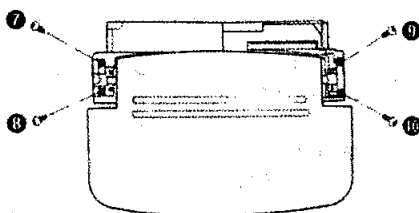
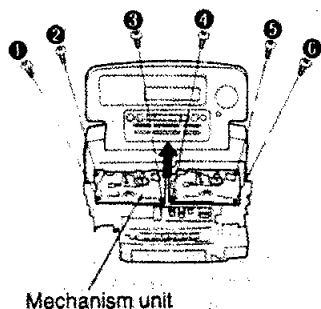

MEASUREMENTS AND ADJUSTMENTS

<TUNER SECTION>

•ALIGNMENT INSTRUCTION

READ CAREFULLY BEFORE ATTEMPTING ALIGNMENT

- Set power source voltage to 15 V DC.
- Set power switch to ON.
- Set function switch to TUNER/MW or LW.
- Set volume level to 5.
- Output of signal generator should be no higher than necessary to obtain an output reading.

•MW-RF ALIGNMENT (The parts other than the ones listed below are aligned at the factory before they are supplied. Therefore, alignment of those parts is unnecessary when used for replacement.)

SIGNAL GENERATOR or SWEEP GENERATOR		RADIO DIAL SETTING	INDICATOR (ELECTRONIC VOLTMETER or OSCILLOSCOPE)	ADJUSTMENT (Refer to Fig. 2.)	REMARKS
CONNECTIONS	FREQUENCY				
Fashion a loop of several turns of wire and radiate a signal into the loop ant. of receiver.	594 kHz	Tune to signal	Headphones Jack (32Ω) (Fabricate the plug as shown in Fig. 1 and then connect the lead wires of the plug to the measuring instrument.)	(*1) L9-1 (MW ANT Coil)	Adjust for maximum output. Adjust L9-1 by moving coil along the ferrite core.
"	1,503 kHz	"	"	CT1 (MW ANT Trimmer)	Adjust for maximum output.

(*1) Fix antenna coil with wax after completing alignment.

•LW-RF ALIGNMENT

SIGNAL GENERATOR or SWEEP GENERATOR		RADIO DIAL SETTING	INDICATOR (ELECTRONIC VOLTMETER or OSCILLOSCOPE)	ADJUSTMENT (Refer to Fig. 2.)	REMARKS
CONNECTIONS	FREQUENCY				
Fashion a loop of several turns of wire and radiate a signal into the loop ant. of receiver.	162 kHz	Tune to signal	Headphones Jack (32Ω) (Fabricate the plug as shown in Fig. 1 and then connect the lead wires of the plug to the measuring instrument.)	(*1) L9-2 (LW ANT Coil)	Adjust for maximum output. Adjust L9-2 by moving coil along the ferrite core.
"	270 kHz	"	"	CT2 (LW ANT Trimmer)	Adjust for maximum output.

(*1) Fix antenna coil with wax after completing alignment.

•ALIGNMENT POINT

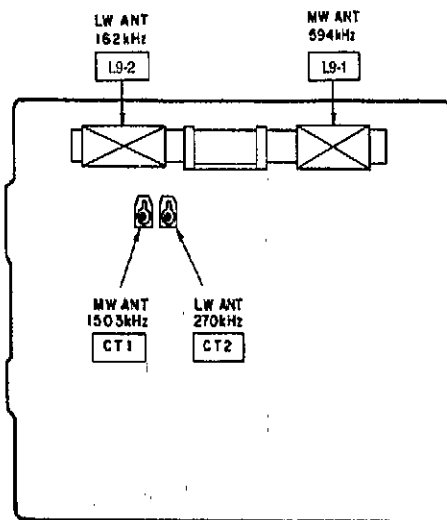
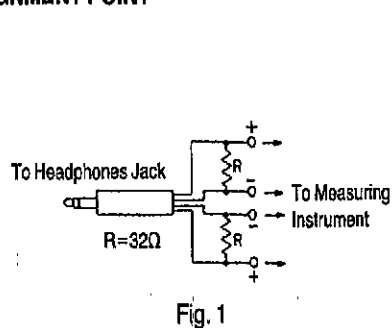

<CASSETTE DECK SECTION>

•ALIGNMENT INSTRUCTION

READ CAREFULLY BEFORE ATTEMPTING ALIGNMENT

- Set power source voltage to 15 V DC.
- Set power switch to ON.
- Set function switch to TAPE.
- Set volume control to 5.
- Output of signal generator should be no higher than necessary to obtain an output reading.

•HEAD AZIMUTH ALIGNMENT

TEST TAPE	INDICATOR (ELECTRONIC VOLTMETER or OSCILLOSCOPE)	ADJUSTMENT	SPECIFICATION	REMARKS
QZZCFM (8 kHz, -20 dB)	Headphones Jack (32Ω) (Fabricate the plug shown in Fig. 1 and then connect the lead wires of the plug to the measuring instrument.)	Azimuth Screw (Refer to Fig. 3.)	maximum output.	1. Playback mode. 2. Adjust for maximum output.

•TAPE SPEED ALIGNMENT

TEST TAPE	INDICATOR (FREQUENCY COUNTER)	ADJUSTMENT	REMARKS
QZZCWAT (3 kHz, -10 dB)	Headphones Jack (32Ω) (Fabricate the plug shown in Fig. 1 and then connect the lead wires of the plug to the measuring instrument.)	DECK 1 NORMAL SPEED VR303 DECK 2 HIGH SPEED VR301 DECK 2 NORMAL SPEED VR302 (Shown in Fig. 4.)	<ol style="list-style-type: none"> 1. Insert test tape (QZZCWAT) in DECK 1 and start playback in forward direction. 2. Adjust VR303 until the frequency is set to 3000 ± 20 Hz. •This frequency is defined as F1. 3. Start playback DECK 1 in reverse direction. 4. Adjust VR303 until the frequency is set to $F1 \pm 40$ Hz. 5. Short the test point TP1 and TP2 to set the high speed mode. 6. Start playback DECK 1 in forward direction. •This frequency is defined as F2. 7. Insert test tape (QZZCWAT) in DECK 2 and start playback in forward direction. 8. Adjust VR301 until the frequency is set to $F2 \pm 40$ Hz. 9. Open the test point TP1 and TP2 to set the normal speed mode. 10. Start playback DECK 2 in forward direction. 11. Adjust VR302 until the frequency is set to 3000 ± 20 Hz. •This frequency is defined as F3. 12. Start playback DECK 2 in reverse direction. 13. Adjust VR302 until the frequency is set to $F3 \pm 40$ Hz.

•RECORD BIAS CHECK

TEST TAPE	INDICATOR (ELECTRONIC VOLTMETER or OSCILLOSCOPE)	ADJUSTMENT	SPECIFICATION	REMARKS
Use METAL tape, CrO ₂ tape and Normal tape	TP6 ... (+) TP4 ... (-) (Shown in Fig. 5.)	—	METAL ... 27 ± 2 mV CrO ₂ ... 18.5 ± 2 mV Normal ... 13 ± 1 mV	•Record mode

•PLAYBACK LEVEL ALIGNMENT

TEST TAPE	INDICATOR (ELECTRONIC VOLTMETER or OSCILLOSCOPE)	ADJUSTMENT (Shown in Fig. 4.)	SPECIFICATION	REMARKS
QZZCFM (315 Hz, 0 dB)	TP9 ... L ch (+) TP2 ... (-) TP10 ... R ch (+)	DECK 1 L ch...VR101 R ch...VR201 DECK 2 L ch...VR102 R ch...VR202	-11 dBV (280 mV) ± 1 dBV	1. Insert test tape (QZZCFM) and start playback. 2. Adjust VR until the electronic voltmeter reaches the value of -11 dBV (280 mV) ± 1 dBV.

•ALIGNMENT POINT

•Please refer to Circuit Board Diagram for test point locations.

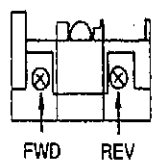
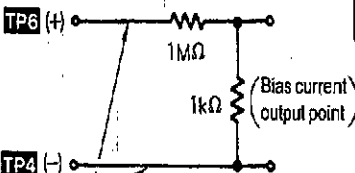

Fig. 3



Keep these cords short. (Line capacitance: 3 pF of less)

•In order not to influence the bias oscillation, divide the voltage with 1 MΩ and 1 kΩ resistors, and measure the voltage across the 1 kΩ resistor.

Fig. 5

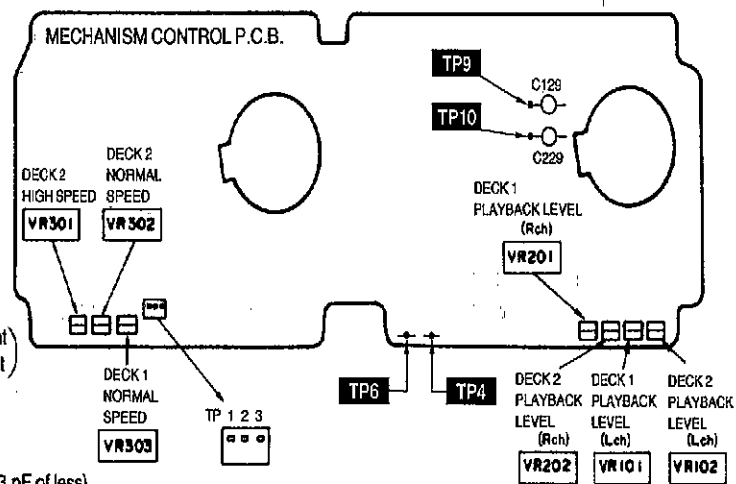

Fig. 4

<CD SECTION>

Caution:

- It is very dangerous to look at or touch the laser beam. (Laser radiation is invisible.)
- With the unit turned "on", laser radiation is emitted from the pickup lens.
- Avoid exposure to the laser beam, especially when performing adjustments.

•The CD P.C.B. requires manual adjustment for all of the following items:

- | | |
|-----------------------------------|------------------------|
| (1) Best eye pattern (PD balance) | (5) Tracking gain |
| (2) Focus offset | (6) Tracking balance |
| (3) Tracking offset | (7) Angle of elevation |
| (4) Focus gain | |

In the RX-DT707 CD P.C.B., a servo processor (IC702: MN66271) automatically adjusts items ② through ⑥ of the seven items listed above. Auto adjustment is performed when:

1. A CD is loaded or replaced, or
2. The unit is turned on with a CD in the drive.

*The auto adjustment procedure is reset when the CD P.C.B. is turned off.

•Preparation for Adjustment

1. Set up the unit following the procedure described in "Checking and Adjusting the CD P.C.B.". (See page 47.)
2. After completing the setup procedure, switch the unit off then switch it on again (to adjust the unit with the CD unit placed in an upright position).

•Locations of Adjustments

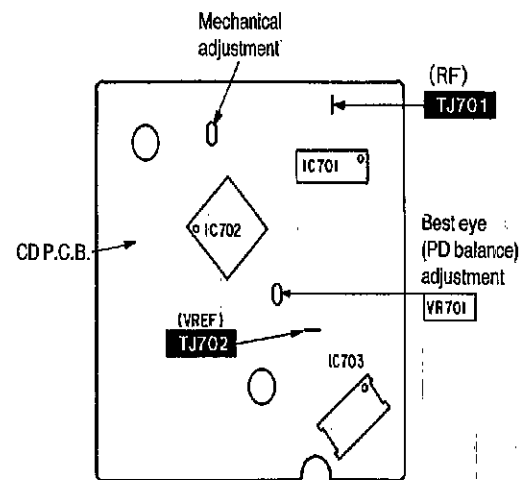

Fig. 6

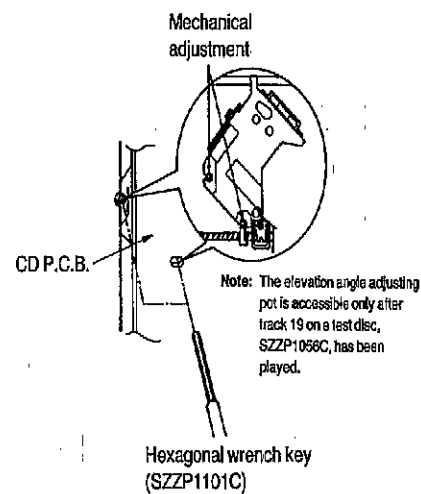

Fig. 7

Measuring Instruments and Special Tools

•Test disc

1. Playability test disc (SZZP1054C)
2. Uneven test disc (SZZP1056C)

•Allen wrench (M2.0) (SZZP1101C)

•Oscilloscope

(1) MECHANICAL ADJUSTMENT

•When the traverse deck is replaced, making adjustments is not necessary. (The traverse deck ass'y is already adjusted.)

•Make adjustments to improve playability when the traverse deck has not been replaced. Make the electrical adjustments first.

1. Connect the oscilloscope's CH.1 probe across **TJ701** (+) and **TJ702** (VREF) on the Servo P.C.B.

Oscilloscope setting:

VOLT 200 mV
SWEEP 0.5 μsec
Input coupling AC

2. Switch the player power ON, and play track 19 on the test disc (SZZP1056C).

3. Leave the player in Play mode and place it as shown in the figure on the right.

4. Alternately adjust the two mechanical adjusting screws with the 2.0 mm allen wrench (SZZP1101C) until the RF signal amplitude on the oscilloscope is maximized. (Shown in Fig. 7)

5. After completing the adjustment, lock the mechanical adjustments with lock paint (RZZ0L01).

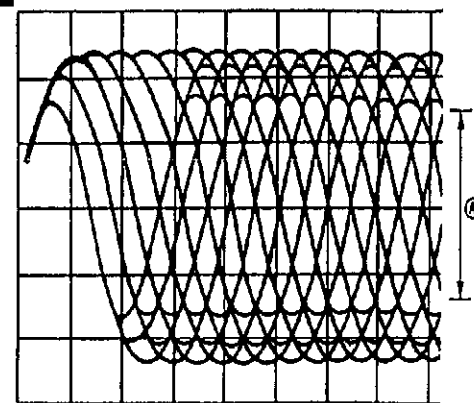

A Maximize the amplitude.

(2) BEST EYE (PD BALANCE) ADJUSTMENT

1. Connect the oscilloscope's CH.1 probe across **TJ701** (+) and **TJ702** (VREF) on the Servo P.C.B.

Oscilloscope setting:

VOLT 200 mV
SWEEP 0.5 μsec
Input coupling AC

2. Switch the player power ON, and play the 1 kHz (track 1) on test disc (SZZP1054C).

3. Adjust VR701 until the RF signal eye pattern amplitude is maximized. (Shown in Fig. 6)

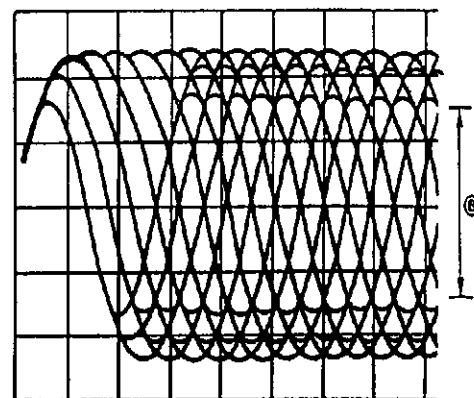

B Maximize the amplitude.

(3) CHECK OF PLAY OPERATION AFTER ADJUSTMENT

*Checking Skip Search

1. Play an ordinary musical program disc.
2. Press the skip button to check for normal skip search operation (in both the forward and reverse directions).

*Checking Manual Search

1. Play an ordinary musical program disc.
2. Press the manual search button to check for smooth manual search operations at either low or high speed (in both the forward and reverse directions).

*Checking Playability

1. Play the 0.7 mm black dot and the 0.7 mm wedge on the test disc (SZZP1054C) and verify that no sound skip or noise occurs.
2. Play the middle tracks of the uneven test disc and verify that no sound skip or noise occurs.

NEW DIGITAL SERVO CIRCUIT

This model employs a new digital servo circuit. Compared to the old digital servo circuit, the following points have been improved.

- 1. Reduced operated noise**
Loading mechanism 2-level speed reducer
- 2. Reduced access time**
[(old) 2.9 seconds → (new) 1.9 seconds]
Change of traverse gear
- 3. Improved vibration resistance**
Rubber and spring 2-level floating mechanism
[$f_0 = 50$ Hz (old) → 20 Hz (new)]
- 4. Reduced number of parts**
Use of a single super IC tip
3 chips (MN6626, MN6650, MN6475) are reduced to a single chip (MN66271)

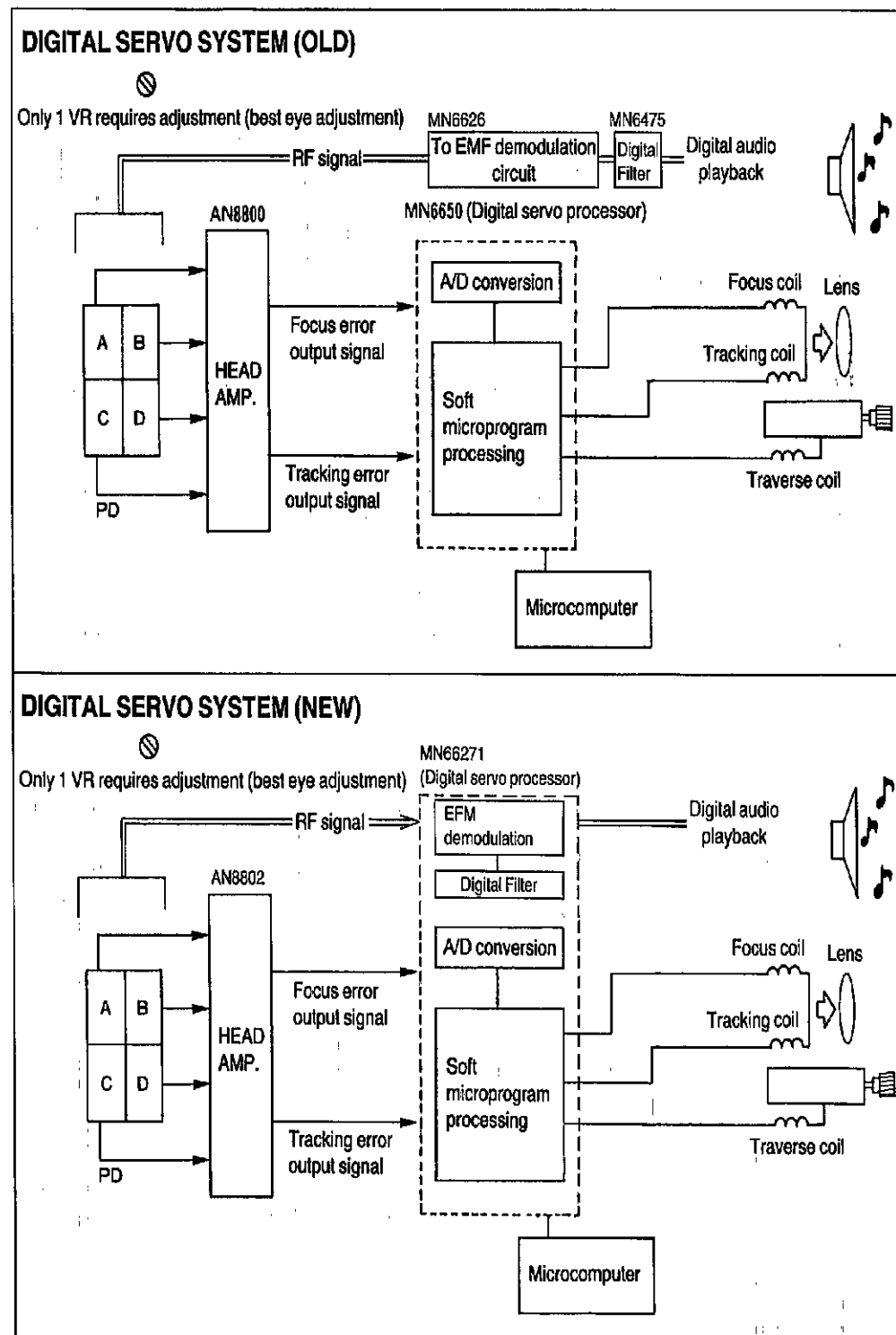

Refer to the service manual for Model No. SL-CH7 (Order No. AD9104084C8) for information on "DIGITAL SERVO SYSTEM" and "CHECKING THE OPERATION PROBLEMS ON THE TRAVERSE DECK (OPTICAL PICKUP)".

SELF DIAGNOSTIC FUNCTION

The Self Diagnostic Function is equipped with RX-DT707. Use this function only when you wish to check the following items.

(It is necessary to use the remote controller supplied with RX-DT707 for the self diagnostic function.)

- Check of malfunction of switches (tact switch) on the cobra top.
Use the diagnostic function when a switch on the cobra top is inoperative.
 - Check of all indications on the LCD
 - Check of LCD short-circuit
- Use the diagnostic function when an LCD is not displayed correctly.

[How to set the self diagnostic function]

Follow the procedures outlined below to set the self diagnostic function mode before the self diagnostic function.

1. Connect the AC power cord of the RX-DT707 to an AC outlet and turn it on.
2. Press the "4" button and afterward "7" button the remote controller while keeping the TAPE/□ button pressed.
The indication in Fig. 1 will be displayed.

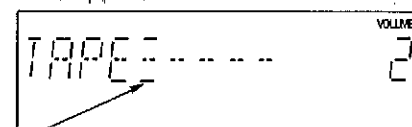

--- : Denotes the RX-DT707 in the self diagnostic function

Fig. 1

• CHECK OF MALFUNCTION OF SWITCHES (Tact switch on the cobra top)

1. Press the "3" button on the remote controller.
• All indications on the LCD will disappear and the LED on the cobra top will blink sequentially from left to right.
2. If you press the buttons on the cobra top in the order of ①, ②, ③ and ④ shown in fig. 2, the LCD will appear in the order as shown in fig. 3.

The LEDs blink sequentially from left to right.

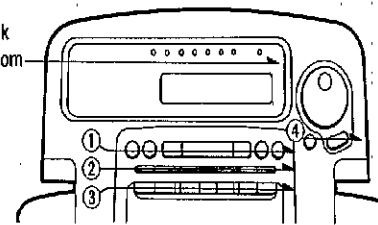

Fig. 2

• The LCD appears in the order as shown in Fig. 3.



Fig. 3



Fig. 4

If the display appears as shown in Fig. 4, the tact switch is normal. If a part of the LCD is not lit, set the self diagnostic function mode again to find the defective switch that cannot light the LCD.

• CHECK OF ALL INDICATIONS ON THE LCD

- Press the "8" button on the remote controller. All indications will appear for about 1 second on the LCD. (Refer to Fig. 5.)
If an indication is not displayed, the LCD or the LCD drive system is defective.

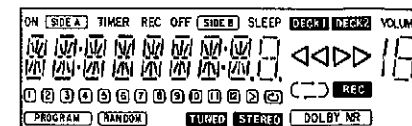

Fig. 5

• CHECK OF LCD SHORT-CIRCUIT

- Press the "9" button on the remote controller. The indications will appear as shown in Fig. 6.
If another indication appears, the LCD is defective.

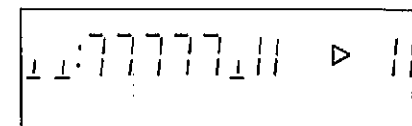
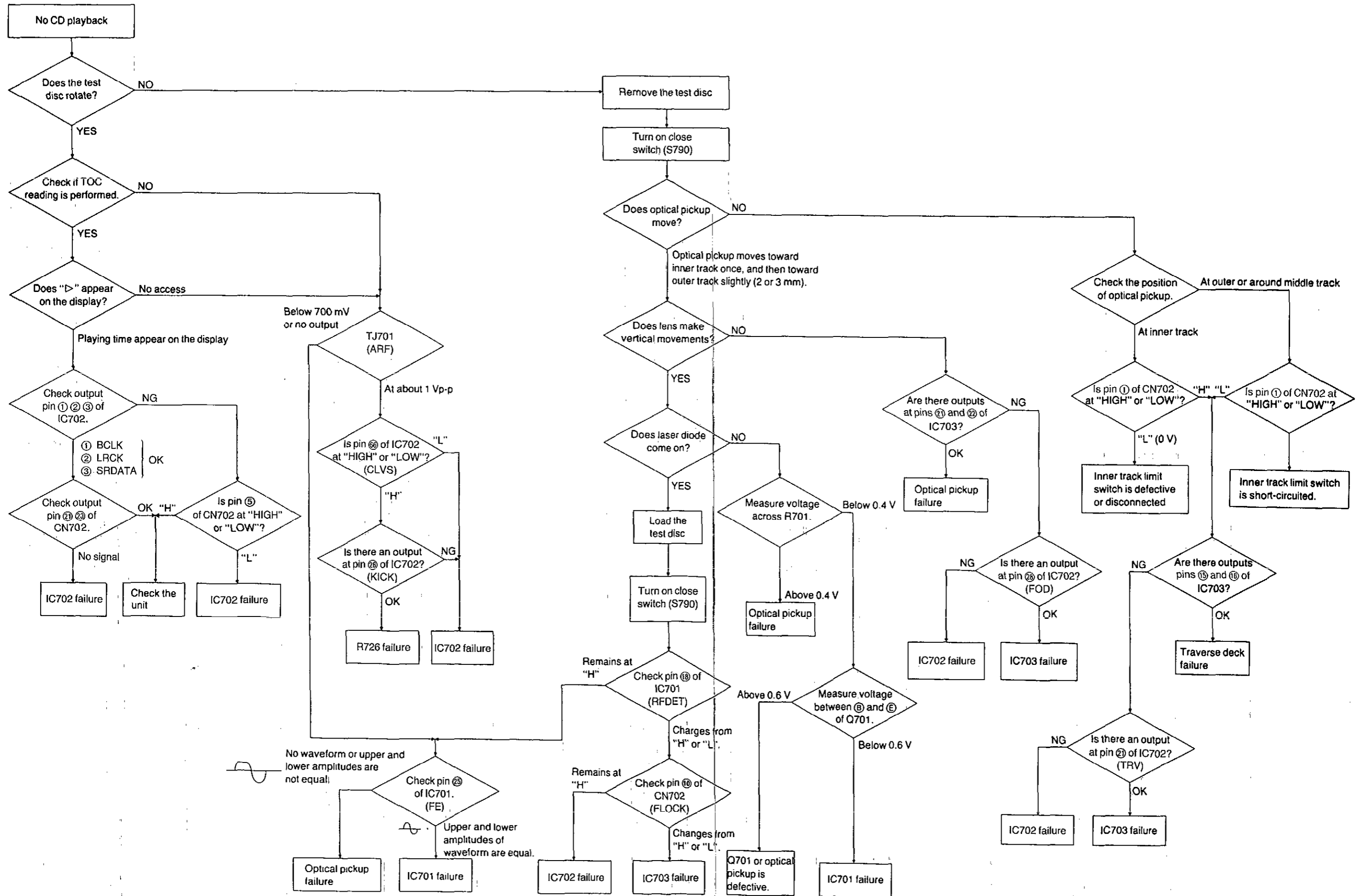

Fig. 6

■ TROUBLESHOOTING GUIDE



■ FUNCTION OF IC TERMINALS

●IC603 (M50253P) (The same IC is employed in IC305 and IC603.)

Pin No.	Terminal Name	I/O	Function																									
1	GND	—	GND																									
2	AG DATA	I	AG data signal input																									
3	AG CLK1	I	AG clock signal input																									
4	CD L	O	Function control signal output <table border="1"> <thead> <tr> <th>Pin No.</th> <th>CD</th> <th>TAPE</th> <th>TUNER</th> <th>AUX</th> </tr> </thead> <tbody> <tr> <td>4</td> <td>L</td> <td>H</td> <td>H</td> <td>H</td> </tr> <tr> <td>5</td> <td>H</td> <td>L</td> <td>H</td> <td>H</td> </tr> <tr> <td>6</td> <td>H</td> <td>H</td> <td>L</td> <td>H</td> </tr> <tr> <td>7</td> <td>H</td> <td>H</td> <td>H</td> <td>L</td> </tr> </tbody> </table>	Pin No.	CD	TAPE	TUNER	AUX	4	L	H	H	H	5	H	L	H	H	6	H	H	L	H	7	H	H	H	L
Pin No.	CD			TAPE	TUNER	AUX																						
4	L			H	H	H																						
5	H			L	H	H																						
6	H	H	L	H																								
7	H	H	H	L																								
5	TAPE L																											
6	TUNER L																											
7	AUX L																											
8	MONO/STEREO	O	<table border="1"> <thead> <tr> <th>AM</th> <th>FM STEREO</th> <th>FM MONO</th> </tr> </thead> <tbody> <tr> <td>H</td> <td>L</td> <td>H</td> </tr> </tbody> </table>	AM	FM STEREO	FM MONO	H	L	H																			
AM	FM STEREO	FM MONO																										
H	L	H																										
9	VOLATT	O	Electric volume muting (-10 dB)																									

Pin No.	Terminal Name	I/O	Function															
10	TOP OPEN	O	Cobra top open/close <table border="1"> <thead> <tr> <th>Pin No.</th> <th>CLOSE</th> <th>OPEN</th> <th>BRAKE</th> <th>OUTPUT OPEN</th> </tr> </thead> <tbody> <tr> <td>10</td> <td>L</td> <td>H</td> <td>H</td> <td>L</td> </tr> <tr> <td>11</td> <td>H</td> <td>L</td> <td>H</td> <td>L</td> </tr> </tbody> </table>	Pin No.	CLOSE	OPEN	BRAKE	OUTPUT OPEN	10	L	H	H	L	11	H	L	H	L
Pin No.	CLOSE			OPEN	BRAKE	OUTPUT OPEN												
10	L	H	H	L														
11	H	L	H	L														
11	TOP CLS																	
12	ATT0	O	ATLS position <table border="1"> <thead> <tr> <th>Pin No.</th> <th>+3 dB</th> <th>0 dB</th> <th>-3 dB</th> <th>-6 dB</th> </tr> </thead> <tbody> <tr> <td>12</td> <td>L</td> <td>H</td> <td>L</td> <td>H</td> </tr> <tr> <td>13</td> <td>L</td> <td>L</td> <td>H</td> <td>H</td> </tr> </tbody> </table>	Pin No.	+3 dB	0 dB	-3 dB	-6 dB	12	L	H	L	H	13	L	L	H	H
Pin No.	+3 dB			0 dB	-3 dB	-6 dB												
12	L	H	L	H														
13	L	L	H	H														
13	ATT1																	
14	LD CLOSE	O	Disc tray open/close <table border="1"> <thead> <tr> <th>Pin No.</th> <th>CLOSE</th> <th>OPEN</th> <th>BRAKE</th> <th>OUTPUT OPEN</th> </tr> </thead> <tbody> <tr> <td>14</td> <td>L</td> <td>H</td> <td>H</td> <td>L</td> </tr> <tr> <td>15</td> <td>H</td> <td>L</td> <td>H</td> <td>L</td> </tr> </tbody> </table>	Pin No.	CLOSE	OPEN	BRAKE	OUTPUT OPEN	14	L	H	H	L	15	H	L	H	L
Pin No.	CLOSE			OPEN	BRAKE	OUTPUT OPEN												
14	L	H	H	L														
15	H	L	H	L														
15	LD OPEN																	
16	VDD	I	+5 V															

●IC305 (M50253P) (The same IC is employed in IC305 and IC603.)

Pin No.	Terminal Name	I/O	Function								
1	VSS	GND									
2	DATA	I	Deck control data input								
3	CLK	I	Deck control clock input								
4	TAPE L	O	Function select (at "TAPE" position) <table border="1"> <thead> <tr> <th>CD</th> <th>TAPE</th> <th>TUNER</th> <th>AUX</th> </tr> </thead> <tbody> <tr> <td>"HIGH"</td> <td>"LOW"</td> <td>"HIGH"</td> <td>"HIGH"</td> </tr> </tbody> </table>	CD	TAPE	TUNER	AUX	"HIGH"	"LOW"	"HIGH"	"HIGH"
CD	TAPE			TUNER	AUX						
"HIGH"	"LOW"	"HIGH"	"HIGH"								
5	HI SP										
6	DOLBY	O	Not used								
7	BP H	O	Beat proof control signal output								

Pin No.	Terminal Name	I/O	Function
8	DMT	O	Deck muting control signal output
9	AGC OFF	O	AGC OFF control signal output
10	1H	O	Playback head select signal output
11	REC	O	Recording control signal output
12	2M	O	DECK 2 motor control signal output
13	1M	O	DECK 1 motor control signal output
14	2PL	O	DECK 2 plunger control signal output
15	1PL	O	DECK 1 plunger control signal output
16	VDD	I	+5 V

●IC701 (AN8802SCE1V)

Pin No.	Terminal Name	I/O	Function
1	PDAD	I	PD A channel signal input with delay
2	PDA	I	PD A channel signal input without delay
3	LPD	I	Laser PD connection
4	LD	O	Power supply for LD driving
5	AMPI	I	RF amplifier input
6	Vcc	I	Power supply connection
7	AMPO	O	RF amplifier output (no use, open)
8	CAGC	I	AGC loop filter connection
9	ARF	O	RF AGC output
10	CENV	I	Capacitor connection for RF detection
11	CEA	I	Capacitor connection for HPF amplifier
12	GND	—	Ground connection
13	LDON	I	ON/OFF input of LD APC ("H": ON, "L": OFF)
14	TES	I	Tracking error shunt signal input ("H": shunt)
15	PLAY	I	Play signal input ("H": PLAY)
16	WVEL	I	WVEL control
17	BDO	O	BDO output
18	/RFDET	O	NRFDET output
19	CROSS	O	CROSS output
20	OFTR	O	OFTR output
21	VDET	O	VDET output
22	ENV	O	ENV output
23	TEBPF	I	Vibration detection input
24	TE	O	Tracking error output
25	FE	O	Focus error output
26	PTO	O	Potential amplifier output (no use, open)
27	PTI	I	Potential amplifier inversion input (no use, open)
28	TBAL	I	Tracking balance input
29	FBAL	I	Focus balance input
30	VREF	O	VREF output
31	PDB	I	PD B channel signal input without delay
32	PDBD	I	PD B channel signal input with delay

●IC702 (MN66271RA)

Pin No.	Terminal Name	I/O	Function
1	BCLK	O	Bit clock output for serial data (no used, open)
2	LRCK	O	L/R identification signal output (no use, open)
3	SRDATA	O	Serial data output (no used, open)
4	DVcc1	I	Power supply input (for digital circuit)
5	DVss1	—	GND (for digital circuit)
6	TX	O	Digital audio interface signal output
7	MCLK	I	Microprocessor command clock signal input (Latches data at first transition)
8	MDATA	I	Microprocessor command data signal input
9	MLD	I	Microprocessor command load signal input
10	SENSE	O	Sence signal output (OFT, FESL, MAGEND, NAJEND, POSAD, SFG)
11	/FLOCK	O	Focus servo feeding signal output ("L": Feed)
12	/TLOCK	O	Tracking servo feeding signal output ("L": Feed)
13	BLKCK	O	Sub-code block clock signal output (IBLKCK=75 Hz during normal playback)
14	SQCK	I	External clock signal input for sub-code Q register
15	SUBQ	O	Sub-code Q code output
16	DMUTE	I	Muting input ("H": Mute)
17	STAT	O	Status signal output (CRC, CUE, CLVS, TTSTVP, FCLV, SQCK)
18	/RST	I	Reset input
19	SMCK	O	1/2-divided clock signal of crystal oscillating at MSEL="H" (fSMCK=8.4672 MHz) 1/4-divided clock signal of crystal oscillating at MSEL="L" (fSMCK=4.2336 MHz)
20	PMCK	O	1/192-divided clock signal of crystal oscillating (fPMCK=88.2 KHz) (no use, open)
21	TRV	O	Traverse forced feed output
22	TVD	O	Traverse drive output
23	PC	O	Spindle motor ON signal output ("L": ON)
24	ECM	O	Spindle motor drive signal output (forced mode output)
25	ECS	O	Spindle motor drive signal output (servo error signal output)
26	KICK	O	Kick pulse output
27	TRD	O	Tracking drive output
28	FOD	O	Focus drive output

Pin No.	Terminal Name	I/O	Function
29	VREF	I	D/A (drive) output (TVD, ECS, TRD, FOD, FBAL, TBAL) Reference voltage input
30	FBAL	O	Focus balance adjustment output (no use, open)
31	TBAL	O	Tracking balance adjustment output
32	FE	I	Focus error signal input (analog input)
33	TE	I	Tracking error signal input (analog input)
34	RFENV	I	RF envelope signal input
35	VDET	I	Vibration detection signal input ("H": detection)
36	OFT	I	Off-track signal input ("H": off track)
37	TRCRS	I	Track cross signal input
38	/RFDET	I	RF detection signal input ("L": detection)
39	BDO	I	Dropout signal input ("H": Dropout)
40	LDON	O	Laser on signal output ("H": ON)
41	TES	O	Tracking error shunt signal output ("H": shunt)
42	PLAY	O	Play signal out ("H": PLAY)
43	WVEL	O	Double speed status signal output ("H": Double speed)
44	ARF	I	RF signal input
45	IREF	I	Reference current input
46	DRF	I	DSL bias (no use, open)
47	DSL F	I/O	DSL loop filter
48	PLL F	I/O	PLL loop filter
49	VCO F	I/O	VCO loop filter (no use, open)
50	AV _{DD} 2	I	Power supply input (for analog circuit)
51	AV _{SS} 2	—	GND (for analog circuit)
52	EFM	O	EFM signal output (not use, open)
53	PCK	O	PLL extraction clock output (fPCK=4.321 MHz during normal playback) (no use, open)
54	PDO	O	Phase comparison signal of EFM and PCK signals (no use, open)
55	SUBC	O	Sub-code serial data output (no use, open)
56	SBCK	I	Clock input for sub-code serial data (no use, open)
57	V _{SS}	—	GND
58	X1	I	Crystal oscillating circuit input (f=16.9344 MHz)
59	X2	O	Crystal oscillation circuit output (f=16.9344 MHz)
60	V _{DD}	I	Power supply input (for oscillating circuit)
61	BYTCK	O	Byte clock output (no use, open)

Pin No.	Terminal Name	I/O	Function
62	/CLDCK	O	Sub-code frame clock signal output (fCLDCK=7.35 kHz during normal playback)
63	FCLK	O	Crystal frame clock signal output (fFCLK=7.35 kHz, double=14.7 kHz)
64	PFLAG	O	Interpolation flag output ("H": Interpolation) (no use, open)
65	FLAG	O	Flage output (no use, open)
66	CLVS	O	Spindle servo phase synchronizing signal output ("H": CLV, "L": rough servo) (no use, open)
67	CRC	O	Sub-code CRC checked output ("H": OK, "L": NG) (no use, open)
68	DEMPH	O	De-emphasis ON signal output ("H": ON) (no use, open)
69	RESY	O	Frame resynchronizing signal output (no use, open)
70	/RST2	I	Reset input through MASH circuit ("L": Reset)
71	/TEST	I	Test input
72	AV _{DD} 1	I	Power supply input (for analog circuit)
73	OUTL	O	Left channel audio signal output
74	AV _{SS} 1	—	GND
75	OUTR	O	Right channel audio signal output
76	RSEL	I	RF signal polarity assignment input (at "H" level, RSEL="H"; at "L" level, RSEL=L)
77	CSEL	I	Crystal oscillating frequency designation input ("L": 16.9344 MHz, "H": 33/8668 MHz)
78	PSEL	I	Test input (normally, "L") (no use, open)
79	MSEL	I	Output frequency switching for SMCK terminal "H": SMCK=8.4672 MHz "L": SMCK=4.2336 MHz (no use, open)
80	SSEL	I	Output mode switching of SUBQ terminal ("H": Q code buffer mode)

●IC801 (MND2410READ)

Pin No.	Mark	I/O Division	Function
1	VDD	I	+5 V
2	OSC2	O	Clock output (4 MHz)
3	OSC1	I	Clock input (4 MHz)
4	VSS	—	GND
5	XI	I	Clock input (32 kHz)
6	XO	O	Clock output (32 kHz)
7	VREF-	I	AD converter reference voltage (GND)
8	ADIN7	I	AD converter input (Tape deck switch)
9	ADIN6	I	AD converter input (Tape deck switch)
10	ADIN5	I	AD converter input (Tape deck switch)
11	ADIN4	I	AD converter input (Cobra top open/close)
12	ADIN3	I	AD converter input (Equalizer switch)
13	ADIN2	I	AD converter input (Deck operation switch)
14	ADIN1	I	AD converter input (CD operation switch)
15	ADIN0	I	AD converter input (Operation switch)
16	VREF+	I	AD converter reference voltage (VDD)
17	JOG IN2	I	Jog dial signal input 2
18	JOG IN1	I	Jog dial signal input 1
19	BEEP	O	Beep signal output
20	LUTCH	O	Electric volume control signal output
21	MKDATA	O	Deck control signal output
22	MKCLK	O	Deck control signal output
23	AGCLK	O	Audio signal control clock output
24	AGDATA	O	Audio signal control data output
25	SPCLK	—	GND
26	POWER CONT	O	Power supply circuit control
27	MUTEA	O	Muting control signal output
28	P2	—	GND
29	AGCLK2	O	Audio signal control clock output 2

Pin No.	Mark	I/O Division	Function
30	AGCLK3	O	Audio signal control clock output 3
31	REMOCON IN	I	Remote control signal input
32	BLKCK	I	Sub code block clock input
33	STATUS	I	CD status signal input
34	CD RESET	I	CD reset signal input
35	RST	I	System reset signal input
36	MLD/PLL CL	I/O	CD signal process strove signal input/PLL tuner clock signal output
37	MDAT/PLL CE	I/O	CD signal process data signal input/PLL tuner strove signal output
38	MCLK/PLL DI	I/O	CD signal process clock signal input/PLL tuner data signal output
39	CLDCK	O	CD sub-code clock output
40	SUBQ	I	CD sub-code data input
41	—	—	—
42	—	—	—
43	CM	—	GND
44	TLOCK/TUNED	I	CD tracking signal input/PLL tuner tuning signal input
45	FLOCK/STEREO	I	CD focus lock signal input/PLL tuner stereo signal input
46	REST	I	Rest switch signal input
47	CD OPEN SW	I	Disc tray open detection switch
48	CD CLOSE SW	I	Disc tray close detection switch
49	SENSE	I	CD sense signal input
50	REM STBY	I	Remote control sensor power control
51	POWER DET	I	Power detection signal input
52~93	SEG41~SEG0	O	LCD segment signal output
94~97	COM3~COM0	O	LCD common signal output
98	VLC3	I	LCD bias reference voltage input 3
99	VLC2	I	LCD bias reference voltage input 2
100	VLC1	I	LCD bias reference voltage input 1

●IC703 (AN8389SE1)

Pin No.	Terminal Name	I/O	Function
1	Vcc	I	Power supply
2	VREF	I	VREF input
3	IN4	I	Motor driver (4) input
4	IN3	I	Motor driver (3) input
5	GND	—	Ground connection
6	NC	—	No connection
7	NRESET	I	Reset input
8	GND	—	Ground connection
9	IN2	I	Motor driver (2) input
10	PC2	I	PC2 (power cut) input
11	IN1	I	Motor driver (1) input
12	PC1	I	PC1 (power cut) input (no use, open)

Pin No.	Terminal Name	I/O	Function
13	PVcc1	I	Power supply (1) for driver
14	PGND1	—	Ground connection (1) for driver
15	D1-	O	Motor driver (1) reverse-action output
16	D1+	O	Motor driver (1) forward-action output
17	D2-	O	Motor driver (2) reverse-action output
18	D2+	O	Motor driver (2) forward-action output
19	D3-	O	Motor driver (3) reverse-action output
20	D3+	O	Motor driver (3) forward-action output
21	D4-	O	Motor driver (4) reverse-action output
22	D4+	O	Motor driver (4) forward-action output
23	PGND2	—	Ground connection (2) for driver
24	PVcc2	I	Power supply (2) for driver

●IC805 (BU2040F-T2)

Pin No.	Terminal Name	I/O	Function
1	GND	—	GND
2	AGDATA	I	Data input
3	AGCLK3	I	Clock input
4	TECHNO	O	Surround LED drive signal output
5	FLAT	O	Preset tone LED drive signal output
6	TECHNO IN/OUT	I/O	Surround IN/OUT (IN=L)
7	BP2	O	Beat proof control (bit 2)
8	BP1	O	Beat proof control (bit 1)

Pin No.	Terminal Name	I/O	Function
9	ST/EDIT	O	STEREO (Tuner)/EDIT (CD) LED drive signal output
10	Q6	—	—
11	LINK	O	LINK (CD) LED drive signal output
12	VOCAL	O	"VOCAL" LED drive signal output
13	SOFT	O	"SOFT" LED drive signal output
14	CLEAR	O	"CLEAR" LED drive signal output
15	HEAVY	O	"HEAVY" LED drive signal output
16	VDD	I	+5 V

■ BLOCK DIAGRAM

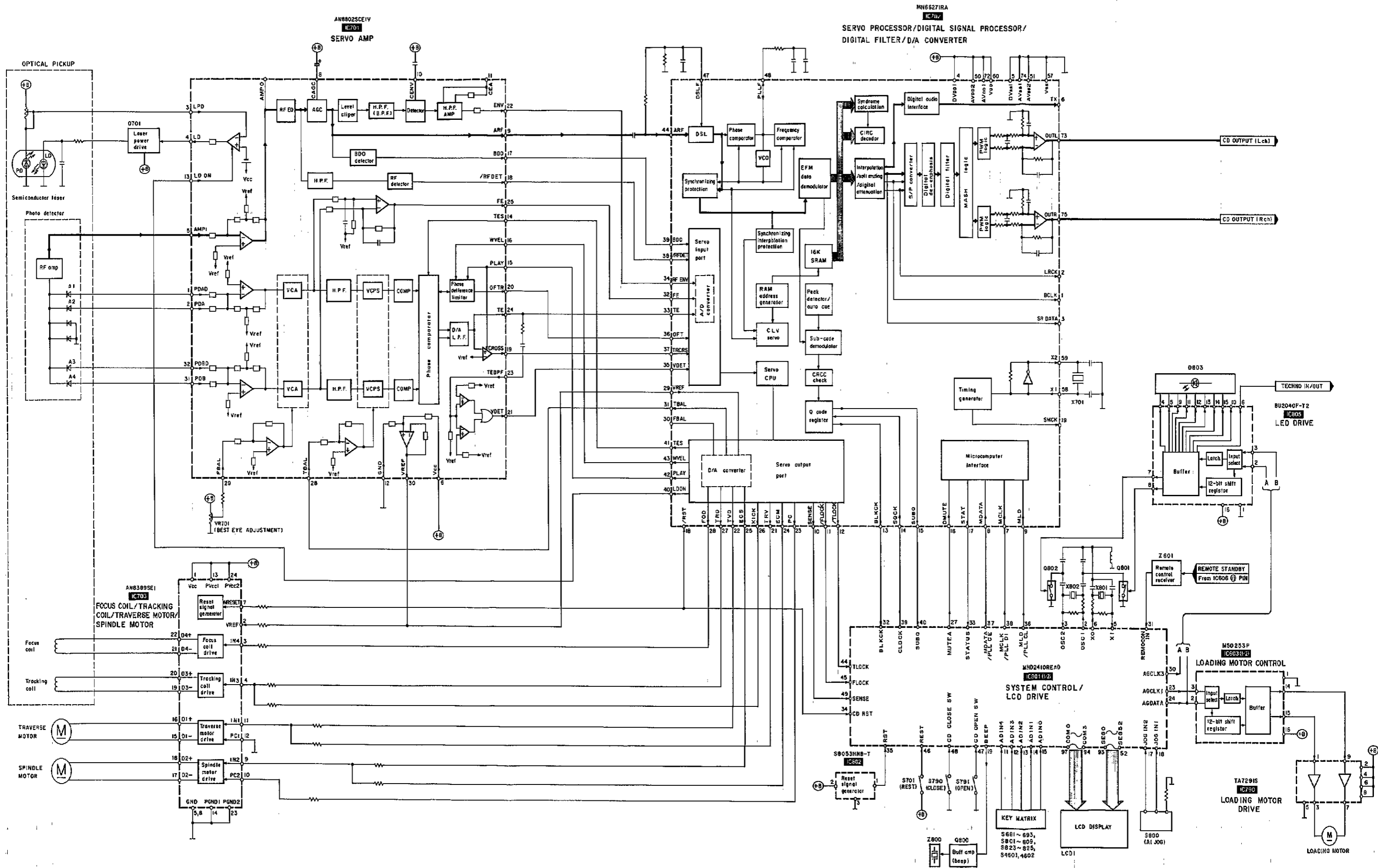

BLOCK DIAGRAM

